



Product Catalog

EarthWise™ CenTraVac™ Water-Cooled Liquid Chillers 120–3950 Tons, 50 and 60 Hz



June 2013

CTV-PRC007-EN



Introduction

World's Most Efficient Lowest Emissions Chiller

Standard of Excellence—Trane found that the straightest path to reliability is simplicity. The Trane CenTraVac™ chiller has only one primary moving part—a single rotating shaft supported by two aircraft-turbine-rated bearings. This direct-drive concept minimizes the chance of failure by reducing the number of critical parts—no gear boxes, couplings, extra shafts, or shaft seals. This also reduces wear and drag on parts, resulting in more sustainable, reliable, and efficient operation.

Environmental Product Declaration—The EarthWise™ CenTraVac centrifugal chiller is the first (and only) commercial chiller in the world to earn Environmental Product Declaration (EPD) registration, following the requirements of ISO 14025. Environmental facts about CenTraVac chillers are now documented and substantiated through third-party Lifecycle Assessment certification. Having an EPD qualifies CenTraVac to earn one LEED® point under Pilot Credit 43, Certified Products.

Economically and Environmentally Sound—The EarthWise CenTraVac has a proven track record as the world's most efficient, lowest emissions chiller. Selectable at an unmatched efficiency level of 0.45 kW/ton at standard AHRI conditions. The full load efficiency levels of CenTraVac chillers are simply the best available, averaging at least 15 percent better than competitive chillers.

Lowest Total Refrigerant Emissions In The Industry—The key to the highest energy efficiency and lowest leak rate is use of the low pressure refrigerant R-123. Semi-hermetic compressors, along with low-pressure refrigerant, produce the industry's lowest real-life, documented refrigerant emissions rate—less than 0.5 percent annually; the closest competitor claims a distant 2.0 percent.

Feedforward Adaptive Control™—CenTraVac chiller control algorithms shorten chiller response time for energy-saving variable pumping strategies. Feedforward is a control strategy designed to anticipate and compensate for load changes via entering water temperatures and flow rates. The controller includes unit-mounted control panel, main processor, and operator interface. Control capabilities include:

- Adaptive Frequency™ Drive control (AFD)
- Variable-primary flow (VPF)
- VPF with AFD
- Soft loading and fast restart
- 34°F (1.1°C) leaving water temperature
- Enhanced Flow Management Package

EarthWise System Design—Reduces first cost, lowers operating costs, and is substantially quieter than traditional applied systems. Central to the design are low flow, low temperature, and high efficiency for both airside and waterside systems, along with optimized control algorithms for sustainable performance.

EarthWise systems are less expensive to install and operate than conventional designs. Trane Integrated Comfort™ Systems (ICS) control technology assures the EarthWise system delivers optimal, reliable performance.

Smaller equipment and ductwork means supplying less airflow at colder temperatures and permits a quieter operation. This also reduces relative humidity in the building, improving indoor air quality.

Compared to conventional designs, an EarthWise chilled water system reduces the total cost of ownership by cutting installation and operational costs. For more information, visit:

http://www.trane.com/Commercial/HvacSystems/1_3_EarthWise.aspx?i=865

Tonnage Ranges by CenTraVac Model Number

CVHE—Three-Stage Single Compressor CenTraVac—50/60 Hz



CVHF—Two-Stage Single Compressor CenTraVac—60 Hz



CVHG—Three-Stage Single Compressor CenTraVac—50 Hz



CDHG—Dual Compressor CenTraVac—50 Hz



CDHF—Dual Compressor CenTraVac—60 Hz



Trademarks

Adaptive Control, Adaptive Frequency, CenTraVac, Duplex, EarthWise, Integrated Comfort, TRACE, Tracer, Tracer AdaptiView, Tracer Summit, Trane, and the Trane logo are trademarks or registered trademarks of Trane in the United States and other countries. All trademarks referenced in this document are the trademarks of their respective owners.

AMPGARD and Cutler-Hammer are registered trademarks of Eaton Corporation; BACnet is a registered trademark of American Society of Heating, Refrigerating and Air-Conditioning Engineers (ASHRAE); DuPont is a trademark and Suva is a registered trademark of E. I. du Pont de Nemours and Company or its affiliates; Echelon, LONMARK, and LonTalk are registered trademarks of Echelon Corporation; The Future Build™ is a trademark of The Future Build; Green Seal is a trademark of Green Seal, Inc., and is used by permission; Intel and Pentium are registered trademarks of Intel Corporation; LEED is a registered trademark of the U.S. Green Building Council; Microsoft, Windows, and Windows Vista are registered trademarks of Microsoft Corporation.

Meets the Green Seal™ standard for High Energy Efficiency, Low Ozone Depleting Refrigerant and Low Refrigerant Emissions.



DuPont™ Suva® refrigerants



Table of Contents

Introduction	2
General Information	6
Features and Benefits	7
Comparing the Attributes of Low- and High-Pressure Chiller Operation ...	7
Backed by the New and Improved 0.0% Leak-Tight Warranty	8
Standard Features	9
Optional Features	10
Factory Testing for Assured Performance	11
The CenTraVac Chiller Operating Cycle	12
CenTraVac Two-Stage and Three-Stage P-H Diagrams	15
Unit Options	17
Trane Starters and Drives	17
Enhanced Electrical Protection Package Options	29
Free Cooling Allows Reduced Operating Costs	30
System Options	34
Heat Recovery	34
Auxiliary Condenser for Economical Heat Recovery	37
Ice Storage Provides Reduced Electrical Demand	39
Application Considerations	41
Condenser Water Control	41
Electrical Information	42
Selection Procedure	43
Selection	43
Full-Load and Part-Load Performance	44
Performance Data	45
Job Site Considerations	49
Supply and Motor Lead Wiring and Connections	49
Shipment and Assembly	50
Controls	51
Tracer AdaptiView Controller	51
Tracer AdaptiView Control and Operator Interface	52
Tracer TU Interface	53
Extended Operation Package	55
Enhanced Flow Management Package	56

LonTalk Communications Interface (LCI-C)	59
Native BACnet Communications	59
Modbus Communications	59
Building Automation and Chiller Plant Control	60
Standard Protections	62
Enhanced Protection Option	66
Weights	67
Physical Dimensions	69
Single Compressor CenTraVac Chillers	69
Dual Compressor CenTraVac Chillers	72
Chiller Views	74
Evaporator Waterbox Configuration	75
Condenser Waterbox Configuration	78
Waterbox Lengths	80
Marine Waterbox Arrangement Tables	82
Mechanical Specifications	83
Compressor	83
Evaporator	84
Condenser/Heat Recovery Condenser	85
Economizer	85
Purge System	85
Chiller Controller	86
Isolation Pads	87
Refrigerant and Oil Charge	87
0.0% Leak-Tight Warranty	88
Thermometer Wells and Sight Glasses	88
Insulation	88
Refrigerant Pumpout/Reclaim Connections	88
Painting	88
Unit-Mounted Starter Options	88
Unit-Mounted, Refrigerant Cooled Adaptive Frequency Drive (AFD)	89
Chiller Unit Controller Features for all Trane AFDs	89
Environmental Ratings	89
Unit-Mounted Refrigerant-Cooled Trane AFD Design Features	90



General Information

Unmatched Local Expertise

The performance and reliability of a CenTraVac chiller is backed by a local team of engineers. These engineers can help answer your questions or solve your problems regarding system design application, installation, or evaluation equipment alternatives. No other manufacturer can offer that degree of support to its customers.

Delivery and Design Flexibility

If delivery time is a priority, Trane can meet your needs with a variety of quick shipment choices. Most fast-track building schedules can be met with one of these choices.

Design flexibility means that Trane can custom build a unit to specific job requirements. Design parameters such as shell type, compressor, waterside pressure drop, as well as full- and part-load performance can be built to meet requirements.

ISO 9001 Certification

ISO 9001 Certified Quality System applies to Trane CenTraVac centrifugal chillers. The system documents office, manufacturing, and testing procedures for maximum consistency in meeting or exceeding customer expectations. ISO 9001 requires extensive documentation on how quality assurance activities are managed, performed, and continuously monitored. Included in the system are verification checkpoints from the time the order is entered until final shipment. In addition, product development is subjected to formal planning, review, and validation.

Certified AHRI Performance

Trane® centrifugal chillers are rated within the scope of the AHRI program and display the AHRI symbol of compliance to certification sections of AHRI Standard 550/590. The EarthWise purge is rated in accordance with AHRI Standard 580.

The applications in this catalog specifically excluded from the AHRI certification program are:

- Free cooling
- Low temperature applications, including ice storage
- 60 Hz chillers above 3,000 tons and/or 15,000 volts
- 50 Hz chillers above 3,000 tons and/or 15,000 volts
- Heat recovery
- Auxiliary condenser
- Glycol and brines

District Cooling

Trane Adaptive Control algorithms and multistage design allow all CenTraVac chillers to operate at low leaving water temperatures (e.g., 34°F) without the use of glycol or other freeze inhibitors. This reduces the cost of delivering cooling capacity over long distances. Pre-engineered thermal storage systems using Trane® chillers extend the chillers exceptional reliability to the rest of the district cooling plant.

Turbine Inlet Cooling

Trane® chillers are frequently used in conjunction with combustion turbines to increase the power capacity, efficiency, and life of the turbine. Turbine inlet cooling can eliminate the need for inlet water spray to reduce NO_x emissions. With turbine inlet cooling, plants can delay or even avoid the need for additional turbines because more capacity is obtainable from existing turbines.



Features and Benefits

Comparing the Attributes of Low- and High-Pressure Chiller Operation

Trane CenTraVac chillers feature a time-tested and proven low-pressure design utilizing the environmentally friendly R-123. They provide the safety of low-pressure with continued product enhancements in leak-tight design. Consider the benefits of a low-pressure CenTraVac chiller versus higher pressure machines:

Table 1. Low pressure to high pressure comparison at AHRI conditions

	Low Pressure	Medium/High Pressure
Evaporator	<ul style="list-style-type: none"> • Always at negative pressure • Air leaks inward • Refrigerant lost: (# air leak in) x purge efficiency^(a) • No refrigerant loss into equipment room 	<ul style="list-style-type: none"> • Always at positive pressure • Refrigerant leaks outward at moderate rate • Refrigerant loss is difficult to know, performance is degraded • Refrigerant loss is into equipment room
Condenser	<ul style="list-style-type: none"> • Usually at neutral to negative pressure during inactivity (air might leak inward) • At slightly positive pressure during operation • Refrigerant leaks outward at very low rate during operation 	<ul style="list-style-type: none"> • Always at high positive pressure • Refrigerant leaks outward at very high rate
Monitoring of leak rate	<ul style="list-style-type: none"> • Trane EarthWise purge is able to continuously monitor in leakage with the run meter of whether the chiller is on or off. • Refrigerant monitor as required by ASHRAE. • Purge can be connected to a building automation system for notification of increased purge operation (in-leak). Similarly, the refrigerant monitor can be connected to the building automation system. 	<ul style="list-style-type: none"> • Only ways to monitor leak rate on high pressure chiller are: <ul style="list-style-type: none"> • periodic leak checks • purchase refrigerant monitor • Refrigerant monitor as required by ASHRAE. • Normally the only time that a leak is detected on a high pressure chiller is during spring startup. This means that a chiller which develops a leak in the summer may leak continuously until the following spring.
Typical Pressures (38°F evap.) (100°F cond.)	<p>R-123</p> <p>Evap: -9.2 psig (-18.1 in. Hg)</p> <p>Cond: 6.1 psig</p>	<p>R-134a</p> <p>Evap: 33.1 psig</p> <p>Cond: 124.1 psig</p>

(a) Trane EarthWise purge efficiency does not exceed 0.02 lb-refrigerant/lb-air.



Backed by the New and Improved 0.0% Leak-Tight Warranty

Leak Tight Warranty Terms and Conditions

The Company warrants for the lesser of 60 months from initial start-up or 66 months from date of shipment that the CenTraVac™ chiller will be leak-tight against refrigerant loss or the Company will furnish replacement refrigerant (the limited "Leak-Tight Warranty"). The limited Leak-Tight Warranty covers CenTraVac chillers (models CVHE/F/L, CVHS and CDHF) installed in the United States and Canada that ship from the factory in La Crosse, Wisconsin, September 1, 2004 or later. **The Company's obligations and liabilities under this warranty are limited to furnishing replacement refrigerant; no other parts or labor are covered under this limited warranty.** No liability whatever shall attach to the Company until appropriate actions (acceptable to Company) have been taken to eliminate the source of the leak.

If the chiller is placed under a comprehensive Trane service and maintenance agreement (Trane "Select Agreement" or better) prior to the expiration of the standard Leak-Tight Warranty, the protection against refrigerant loss shall continue under the Trane Select Agreement for as long as an active Trane Select Agreement remains in effect without interruption.

If a 10-Year Parts, Labor and Refrigerant Warranty was purchased for the chiller and the chiller is placed under the Trane Select Agreement (or better) prior to the expiration of the 10-Year Parts, Labor and Refrigerant Warranty, the protection against refrigerant loss shall continue under the Trane Select Agreement for as long as an active Trane Select Agreement remains in effect without interruption.

Any further warranty must be in writing, signed by an authorized representative of the Company.

NOTWITHSTANDING ANYTHING TO THE CONTRARY, IN NO EVENT SHALL THE COMPANY BE LIABLE FOR ANY INCIDENTAL OR CONSEQUENTIAL DAMAGES EVEN IF A PARTY HAS BEEN ADVISED OF SUCH POSSIBLE DAMAGES OR IF SAME WERE REASONABLY FORESEEABLE AND REGARDLESS OF WHETHER THE CAUSE OF ACTION IS FRAMED IN CONTRACT, NEGLIGENCE, ANY OTHER TORT, WARRANTY, STRICT LIABILITY, OR PRODUCT LIABILITY.

Standard Features

The following features are provided as standard with all Trane CenTraVac chillers:

- Tracer™ chiller control strategies.
- 12.1-in. Color LCD display, with intuitive animated interface, on articulating arm.
- BACnet® and Modbus BAS communications direct from the chiller.
- Prewired instrument and control panel.
- Two-stage or single-stage flash economizer for enhanced efficiency.
- Tight vessel, low-pressure operation that minimizes the chance for outward refrigerant leaks.
- Minimum five-year **0.0% Leak-Tight Warranty** will provide replacement refrigerant during the first five years and the benefit can be extended with a Trane Select Agreement (or better). Refer to "[Leak Tight Warranty Terms and Conditions](#)," p. 8 and "[0.0% Leak-Tight Warranty](#)," p. 88 for details.
- Hermetically sealed and precision cooled by liquid refrigerant that keeps the motor, drive, and equipment room temperatures controlled, monitored, and predictable by design. Taking predictable reliability to yet another level, this feature also protects against motor-destroying elements such as dust, grit, metal shavings, high humidity, high ambient operating temperatures, and process liquids or gases.
- High efficiency purge system with automatic regeneration capability.
- Purge capability when chiller is off.
- Comprehensive motor control and compressor protection.
- Phase voltage sensors (3-phase).
- Startup and operator instruction service.
- Hot water control and ice-making control.
- Oil heater.
- Oil and refrigerant charge.
- Isolation pads.
- Ability to meet or exceed ASHRAE 90.1-2004, 2007, 2007 add. M, 2010.
- Complies with ASHRAE Standard 147 and ASHRAE Standard 15.
- Wiring and conduit for purge and oil system interconnection to the main control panel.
- On-line tolerance for quick changes in refrigerant loop conditions, variable pumping strategies, and other atypical operating requirements.
- Entering condenser water temperature down to 50°F (10°C) maintaining 3 psid differential pressure.
- Designed to be rugged and simple yet amazingly quiet, the CenTraVac is directly driven at low speed with a motor shaft that is supported by two aircraft-turbine-rated bearings. The design includes industrial-grade components and only one primary moving part. Likewise, the design purposely excludes speed-increasing gears and lightweight parts that, while accessible, have a higher failure rate.

Optional Features

Trane offers a selection of optional features to augment the standard chiller installation or to modify the chiller for special purpose applications.

- Energy saving, factory-mounted free cooling, heat recovery, or auxiliary condenser.
- Proof of predicted performance and sound pressures.
- Leaving water temperature down to 34°F (1.1°C) without glycol.
- Extended operation control for external ice-building, base loading, and providing hot water.
- Chiller break apart (field-easy disassembly).
- Three-pass or one-pass evaporator configuration.
- Refrigerant monitor input for display.
- Enhanced flow management package.
- Enhanced electrical protection packaging of controls and electrical wiring.
- SAE HS-1738 compliance.
- High-pressure (300 psig) water side construction.
- Factory-applied thermal insulation.
- Chilled-water reset based upon outside air temperature.
- Complete line of compressor motor starters—remote and factory-installed, and prewired if unit-mounted.
- Unit-mounted or remote-mounted variable-speed drives.
- Medium-voltage (2,300–6,600 V; 10–13.8 kV) compressor motor.
- Enhanced high-fault, 100,000 short-circuit rating (SCR) starters.
- Special paint and controls for outdoor use or corrosive environments.
- Special tube materials: Titanium, Sea-Cure, Stainless Steel, or CuNi.
- Special tube enhancements: 3/4-in. or 1-in. OD, smooth-bore low fouling, and various tube wall thicknesses.
- UL/CUL label.
- Flow measurement.
- Enhanced condenser limit control.
- Marine waterboxes for evaporators and condensers.
- Waterbox hinges.
- Welded flanges.
- Spring isolators.



Factory Testing for Assured Performance

CenTraVac chillers that fall within AHRI Standard 550/590 requirements bear the AHRI seal. All other CenTraVac chillers, and the selection software itself, are rated in accordance to the standard and fulfill identical performance requirements. Performance testing is a key part of this program. While the certification program is technically sound, a factory run test, with your machine on the test stand, is still the best way to confirm chiller performance and a trouble-free startup.

To prove that your chiller will perform as promised, Trane offers factory performance testing, which you can witness. Testing confirms chiller efficiency, chiller capacity, and makes trouble-free startup significantly more predictable.

Testing is in accordance with AHRI Standard 550/590 and calibration of instrumentation meets or exceeds the National Institute of Standards Technology (NIST).

Trane offers two levels of CenTraVac performance testing:

- A performance test at design conditions plus a certified test report.
- A customer-witnessed performance test at design conditions plus a certified test report.

Note: Most chiller tests are conducted with standard AHRI tolerance; however, zero tolerance testing is available.

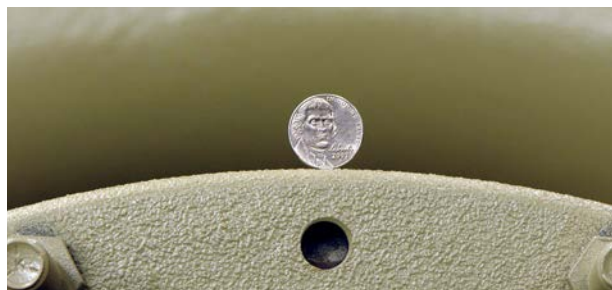

During customer-witnessed performance tests of Trane CenTraVac chillers, a nickel can be balanced on the edge of the compressor-motor assembly. This demonstrates the extremely low vibrations generated by the unit while operating at full- and part-load conditions.

The CenTraVac Chiller Operating Cycle

Figure 1. Two-stage refrigerant flow

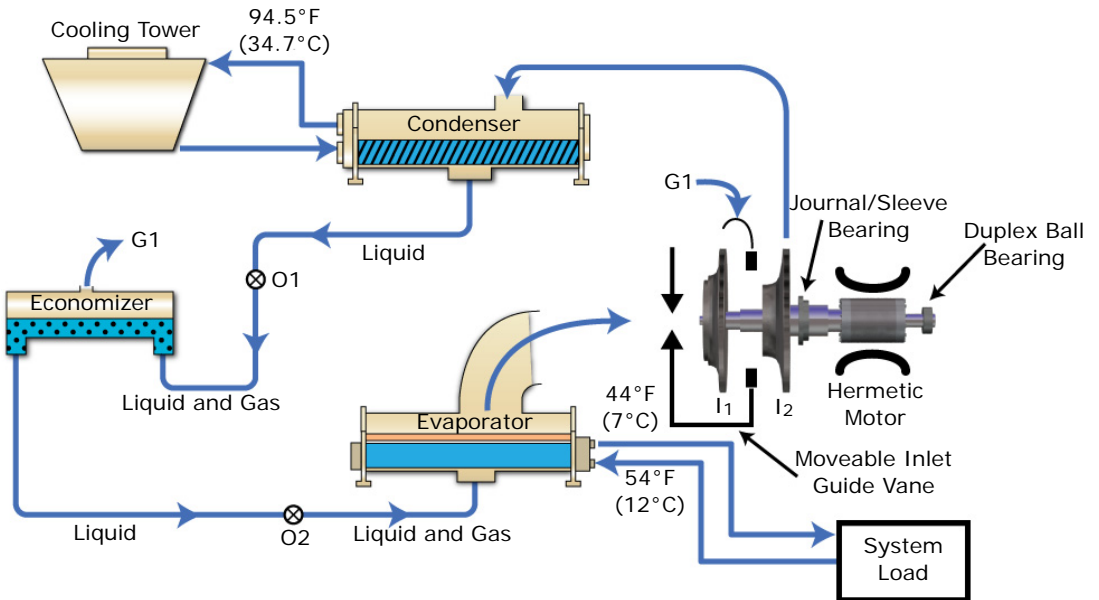
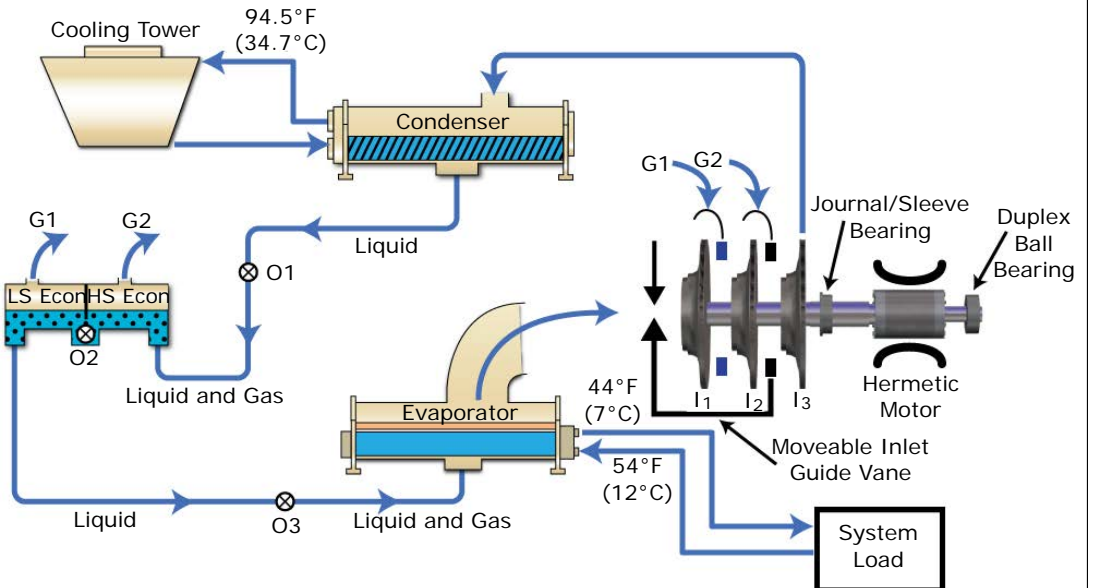

Figure 2. Three-stage refrigerant flow



CenTraVac Motor

The motor provided in the Trane CenTraVac chiller is a specially designed squirrel-cage, two-pole induction motor suitable for 50 and 60 hertz, three-phase current.

Trane CenTraVac motors are cooled by liquid refrigerant surrounding the motor windings and rotor. Using liquid refrigerant results in uniform low temperatures throughout the motor, which prolongs motor life over open designs. Motor heat is rejected out to the tower, which helps keep the equipment room at a desirable temperature.

Design Simplicity

Impellers are keyed directly to the motor shaft for high reliability, performance, and low life-cycle costs.

Fixed Orifice Flow Control

For proper refrigerant flow control at all load conditions, the CenTraVac design incorporates the Trane® patented fixed orifice system. The orifices are optimized for full- and part-load chiller performance during the selection process. It eliminates float valves, thermal expansion valves, and other moving parts. Since there are no moving parts, reliability is increased.

Quiet Operation

With only one primary rotating component—the rotor and impeller assembly—the Trane® low speed, direct-drive design operates exceptionally quiet. The smoothly rotating CenTraVac compressor is inherently quieter than gear-driven compressors. Typical CenTraVac chiller sound measurements are among the quietest in the industry. Trane can guarantee sound levels with factory testing and measurements in accordance with AHRI Standard 575.

The Reliability Standard

Just as a multistage turbine is more efficient than a single-stage turbine, the CenTraVac multistage compressors are more efficient, stable, and reliable than single-stage designs.

Direct-Drive Design—No Gear Losses

The direct-drive compressor operates without speed-increasing gears, thus eliminating gear energy losses. Compressors using gears suffer mesh losses and extra bearing losses in the range of three to five percent at full load. Since these losses are fairly constant over the load range, increasingly larger percentage losses result as load decreases.

Multiple Stages of Compression

The compressor operates more efficiently over a wide range of capacities, virtually eliminating the need for energy wasting hot-gas bypass as typically found on single-stage chillers.

The radial component of velocity determines the ability of the chiller to resist interruption of smooth refrigerant flow when operating at light loads with high condensing temperatures. This interruption in flow and unstable operation, called “surge,” is avoided with the two-stage design.

Inlet Guide Vanes

Part-load performance is further improved through the use of moveable inlet guide vanes. Inlet guide vanes improve performance by throttling refrigerant gas flow to exactly meet part-load requirements and by prerotating refrigerant gas for optimum entry into the impeller. Prerotation of refrigerant gas minimizes turbulence and increases efficiency.

Two-Stage Economizer

The CVHE/CVHG CenTraVac chiller has a two-stage economizer—providing up to seven percent greater efficiency than designs with no economizer. Since the CVHE/CVHG uses three impellers, it



Features and Benefits

The CenTraVac Chiller Operating Cycle

is possible to flash refrigerant gas at two intermediate pressures between the evaporator and condenser, significantly increasing chiller efficiency. This improvement in efficiency is not possible in single-stage chillers because all compression is done by one impeller.

Single-Stage Economizer

The CVHF CenTraVac chiller has a single-stage economizer—providing up to 4-1/2 percent greater efficiency than designs with no economizer.

Since the CVHF CenTraVac uses two impellers, it is possible to flash refrigerant gas at an intermediate pressure between the evaporator and condenser, significantly increasing chiller efficiency. This improvement in efficiency is not possible in single-stage chillers because all compression is done by one impeller.

Refrigerant/Oil Pump Motor

The oil pump motor is a 120 volt, 50/60 hertz, 3/4 hp, 1-phase motor with protective fusing and panel mounted contactor.

EarthWise Purge System

The purge design features a high-efficiency carbon filter with an automatic regeneration cycle. The filter collects and scrubs refrigerant and noncondensable gas and returns collected refrigerant vapor back into the chiller. When the tank senses that it is full, the regeneration cycle begins, and reclaimed refrigerant is automatically returned to the chiller. This keeps the purge efficiency at its peak without the need to exchange carbon cannisters.

Normal operating efficiency does not exceed 0.02 pound of refrigerant lost per pound of dry air removed. The purge system can be operated at any time, independent of chiller operation, per ASHRAE Standard 147.

CentraVac Two-Stage and Three-Stage P-H Diagrams

Figure 3. Three-stage CentraVac P-H diagram

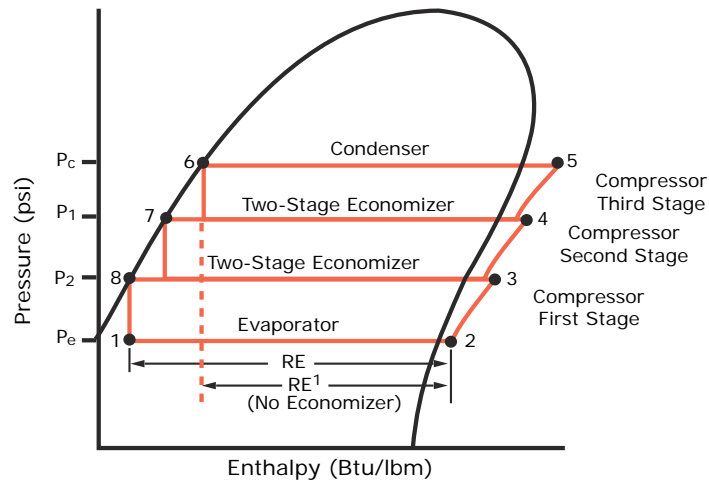
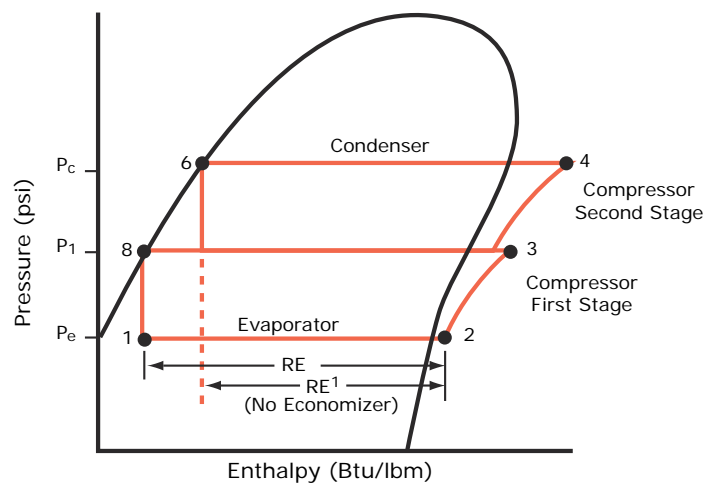

Figure 4. Two-stage CentraVac P-H diagram



The pressure-enthalpy (P-H) diagrams describe refrigerant flow through the major chiller components. The diagrams confirm the superior operating cycle efficiency of the three- and two-stage compressor with economizer, respectively.

Evaporator—A liquid-gas refrigerant mixture enters the evaporator (point 1). Liquid refrigerant is vaporized (point 2) as it absorbs heat from the system cooling load. The vaporized refrigerant then flows into the compressor’s first stage.

Compressor First Stage—Refrigerant gas is drawn from the evaporator into the first stage compressor. The first-stage impeller accelerates the gas increasing its temperature and pressure (point 3).

Compressor Second Stage—Refrigerant gas leaving the first-stage compressor is mixed with cooler refrigerant gas from the low pressure side of the two- or single-stage economizer. This



Features and Benefits

CenTraVac Two-Stage and Three-Stage P-H Diagrams

mixing lowers the enthalpy of the mixture entering the second stage. The second-stage impeller accelerates the gas, further increasing its temperature and pressure (point 4).

Compressor Third Stage—For CenTraVac chillers with three-stage compression, the refrigerant gas leaving the compressor's second-stage is mixed with cooler refrigerant gas from the high pressure side of the two-stage economizer. This mixing lowers the enthalpy of the gas mixture entering the third-stage compressor. The third-stage impeller accelerates the gas, further increasing its temperature and pressure (point 5), then discharges it to the condenser.

Condenser—Refrigerant gas enters the condenser where the system cooling load and heat of compression are rejected to the condenser water circuit. This heat rejection cools and condenses the refrigerant gas to a liquid (point 6).

For three-stage CenTraVac chillers with the patented two-stage economizer and refrigerant orifice system, liquid refrigerant leaving the condenser (Figure 3, p. 15, point 6) flows through the first orifice and enters the high pressure side of the economizer. The purpose of this orifice and economizer is to preflash a small amount of refrigerant at an intermediate pressure (P1). Preflashing some liquid refrigerant cools the remaining liquid (point 7).

Refrigerant leaving the first stage economizer flows through the second orifice and enters the second-stage economizer. Some refrigerant is preflashed at intermediate pressure (P2). Preflashing the liquid refrigerant cools the remaining liquid (point 8).

To complete the operating cycle, liquid refrigerant leaving the economizer (point 8) flows through a third orifice system. Here, refrigerant pressure and temperature are reduced to evaporator conditions (point 1).

For two-stage CenTraVac chillers with economizer and refrigerant orifice system, liquid refrigerant leaving the condenser (Figure 4, p. 15, point 6) flows through the first orifice system and enters the economizer. The purpose of the orifice and economizer is to preflash a small amount of refrigerant at an intermediate pressure (P1) between the evaporator and condenser. Preflashing some liquid refrigerant cools the remaining liquid (point 8).

Another benefit of flashing refrigerant is to increase the total evaporator refrigeration effect from RE¹ to RE. The economizer of two-stage CenTraVac chillers provides a 4-1/2 percent energy savings and the two-stage economizer of the three-stage CenTraVac chillers provides a 7 percent energy savings, compared to chillers with no economizer. To complete the operating cycle, liquid refrigerant leaving the economizer (point 8) flows through a second orifice system. Here, refrigerant pressure and temperature are reduced to evaporator conditions (point 1).

Unit Options

Trane Starters and Drives

A Wide Array of Low- and Medium-Voltage Starters

Trane® starters can be applied to low- or medium-voltage applications. The current draw of the compressor motor determines the size of the starter. The starter size must be greater than, or equal to, the compressor motor current draw.

Table 2. Trane CenTraVac chiller starter and drive choices

Low Voltage (208–600 V)		Medium Voltage (2,300–6,600 V)		Medium Voltage (10–13.8 kV)
Remote-Mounted	Unit-Mounted	Remote-Mounted	Unit-Mounted	Remote-Mounted
Wye-Delta Up to 1,700 amps	Wye-Delta Up to 1,316 amps (Up to 1,120 amps with disconnect/circuit breaker option)	Across-the-Line Up to 360 amps Isolation switch, power fuses standard	Across-the-Line Up to 288 amps Isolation switch, power fuses standard	Across-the-Line Up to 94 amps Isolation switch, power fuses standard
Solid-State (Up to 1,120 amps with disconnect or circuit breaker required)	Solid-State (Up to 1,120 amps with disconnect or circuit breaker required)	Primary Reactor Up to 360 amps Isolation switch, power fuses standard	Primary Reactor Up to 205 amps Isolation switch, power fuses standard	Primary Reactor Up to 94 amps Isolation switch, power fuses standard
Adaptive Frequency Drive 460/480/575/600 V Up to 1,360 amps (460/480 V) 1,120 amps (575/600 V)	Adaptive Frequency Drive Up to 1,210 amps Circuit breaker standard 460–480 V	Autotransformer Up to 360 amps Isolation switch, power fuses standard	Autotransformer Up to 205 amps Isolation switch, power fuses standard	Autotransformer Up to 94 amps Isolation switch, power fuses standard
		Adaptive Frequency Drive Up to 250 amps Isolation switch, power fuses standard		

Overview, Standard and Optional Features

All factory-installed or remote-mounted starters provided by Trane offer the following standard features for safe, efficient application and ease of installation:

Standard Features

- NEMA 1 starter enclosure.
- Starter enclosures capable of being padlocked (unit-mounted wye-delta and solid-state starters).
- 120 volt, 60 hertz, 1-phase fused pilot and safety circuits.
- Control power transformer (4 kVA) producing 120 volt, 50 or 60 hertz, single-phase. This provides auxiliary power for all chiller-mounted devices¹.
- Three-phase incoming line terminals.
- Six output load terminals (three for medium-voltage) factory-connected to the motor.
- Automatic closed-transition transfer from wye to delta on any two-step starter (unit-mounted).
- One pilot relay to initiate start sequence from CenTraVac control circuit signal.

¹ Exception: Remote-mounted medium-voltage AFDs.

Unit Options

Standard and Optional Features on Trane Starters

Optional Features

- Ground fault protection.
- Digital metering devices.
- Surge protector/lighting arrestor.
- Standard, high interrupt, and higher interrupt circuit breakers that are mechanically interlocked to disconnect line power when the starter door is open.
- Special NEMA enclosures.
- Analog ammeters and voltmeters.
- Special function pilot lights.
- Under/over voltage.

Factory-Installed Starters

- Enhances electrical system reliability.
- Factory-tested chiller/starter combination.
- Optimizes control of the CenTraVac motor/compressor start and protection subsystem.
- Factory quality control of the starter-to-chiller electrical connections.
- Eliminates field-installed disconnect switch (when optional circuit breaker is used).
- Reduces the number of field electrical connections.
- Eliminates chiller-to-starter field wiring.
- Reduces starter installation costs 20 percent to 35 percent.
- Complete package available with UL, UL/EEV, or UL/California code agency approval.
- Eliminates starter mounting-pad and required equipment room floor space.
- Eliminates starter-to-disconnect switch field wiring (when optimal circuit breaker is used).
- Reduces system design time-starter components and interconnecting wiring are pre-engineered and selected.

Standard Motor Protection

Three precision current transformers monitor phase current. Contactor position and various voltage signals provide extensive interlocking between the starter and the chiller controller. All logic and subsequent instruction originate in the chiller controller. Protection against the following starter detections is provided:

- Loss of phase
- Distribution fault
- Excessive accelerating time
- Incomplete starting sequence
- Phase reversal
- Improper starter circuitry
- Phase amperage unbalance
- High motor current (starting and running)

Figure 5. Typical equipment room layout: unit-mounted Wye-Delta starter

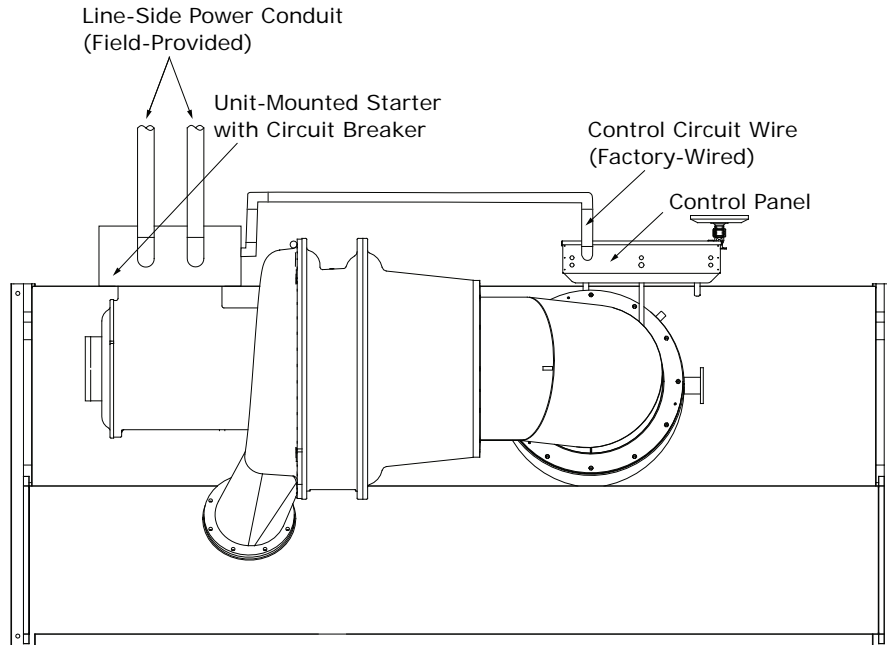
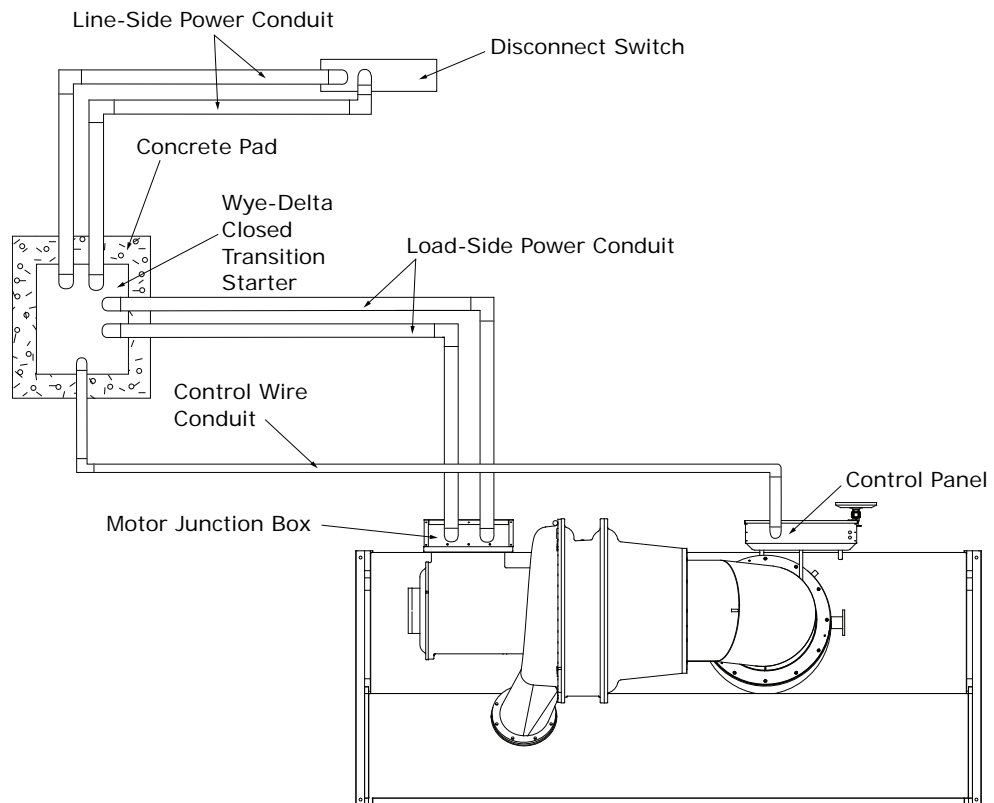

Figure 6. Typical equipment room layout: conventional remote Wye-Delta starter



Unit-Mounted Low-Voltage Wye (Star)-Delta Starters

One of the most common starters in the industry is the wye (star)-delta. It is an electromechanical starter initially set up in a “wye” or “star” configuration, then it transitions to a “delta” configuration during the starting sequence. This starter type can be selected as a unit- or remote-mounted option as shown in [Figure 5, p. 19](#) and [Figure 6, p. 19](#); also refer to [Figure 7](#) for a typical view of the wye-delta starter. When starting and during acceleration, the motor is connected in its wye configuration. Because of this arrangement, the voltage applied to the motor windings is reduced to the inverse of the square root of three or 0.58 times line voltage. This reduction in winding voltage results in a reduction in inrush current. The inrush current is 0.33 times the full-voltage locked rotor current rating of the motor. The accelerating torque of the motor is also reduced to 33 percent the full-voltage torque rating, which is sufficient to fully accelerate the compressor motor. The chiller controller monitors the motor current during operation via current transformers located in the starter enclosure. During acceleration, when the line current drops to approximately 0.85 times rated load current, transition is initiated. The closed transition feature provides for a continuous motor current flow during transition by placing resistors in the circuit momentarily. This prevents the motor from losing phase to the line current during this period. With the completion of transition, the motor windings are connected in the delta configuration with full line voltage.

Additional electrical information is available in CTV-PRB004-EN (*Engineering Bulletin: Starters and Electrical Components for CenTraVac™ Chillers*).

Figure 7.

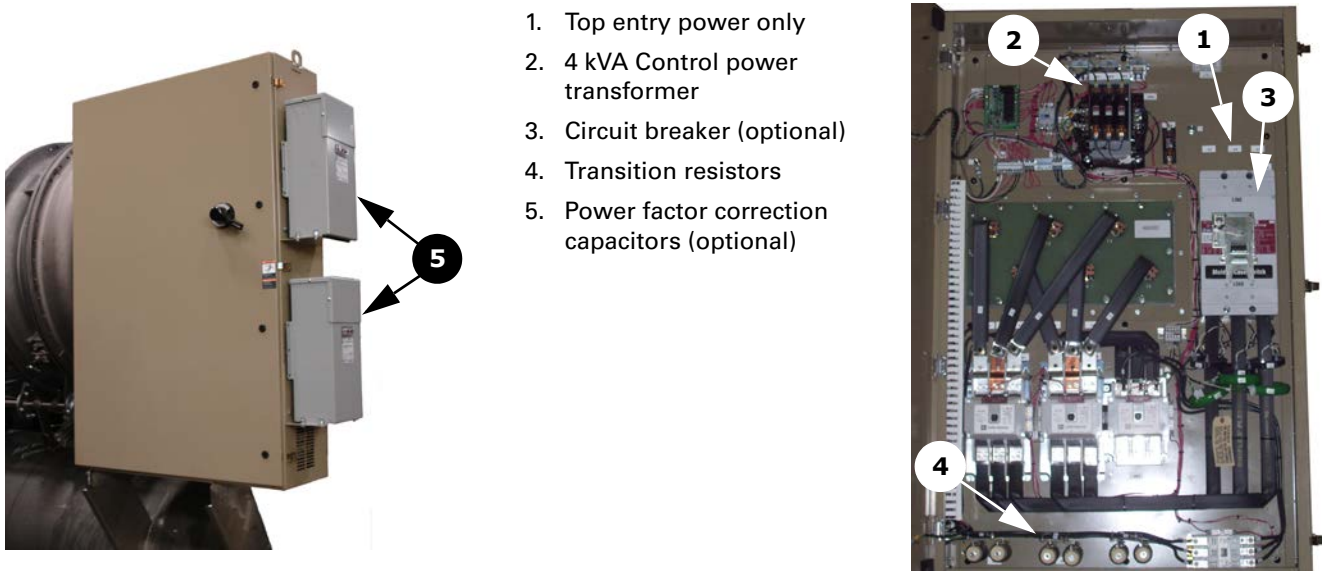

1. Top entry power only
2. 4 kVA Control power transformer
3. Circuit breaker (optional)
4. Transition resistors
5. Power factor correction capacitors (optional)

Unit-Mounted Low-Voltage Solid-State Starters

A solid-state starter controls the starting characteristics of a motor by controlling the voltage to the motor. It does so through the use of SCRs (Silicon Controlled Rectifiers), which are solid-state switching devices, and an integral bypass contactor for power control.

Silicon Controlled Rectifiers (SCR)

An SCR will conduct current in one direction only when a control signal (gate signal) is applied. Because the solid-state starter is for use on AC (alternating current), two SCRs per phase are connected in parallel, opposing each other so that current may flow in both directions. For three-phase loads, a full six-SCR configuration is used.

During starting, control of current or acceleration time is achieved by gating the SCR on at different times within the half-cycle. The gate pulses are originally applied late in the half-cycle and then gradually applied sooner in the half-cycle. If the gate pulse is applied **late in the cycle**, only a **small increment of the wave form** is passed through, and the **output is low**.

If the gate pulse is applied **sooner in the cycle**, a greater increment of the wave form is passed through, and **the output is increased**. So, by controlling the SCRs output voltage, the motor's acceleration characteristic and current inrush can be controlled.

Integral Bypass Contactors

When the SCRs are fully "phased on," the integral bypass contactors are energized. The current flow is transferred from the power pole to the contactors. This reduces the energy loss associated with the power pole, which otherwise is about one watt per amp per phase.

When the starter is given the stop command, the bypass contactors are de-energized, which transfers the current flow from the contactors back to the power poles. The SCRs are then turned off, and the current flow stops.

Because the SCRs are turned off during normal operation, the design can be air-cooled and harmonic currents are not an issue.

Additional electrical information is available in CTV-PRB004-EN (*Engineering Bulletin: Starters and Electrical Components for CenTraVac™ Chillers*).

Figure 8.



1. Top entry power only
2. 4 kVA Control power transformer
3. Circuit breaker
4. Intelligent technology (IT) controller
5. Starter control board
6. Potential transformers

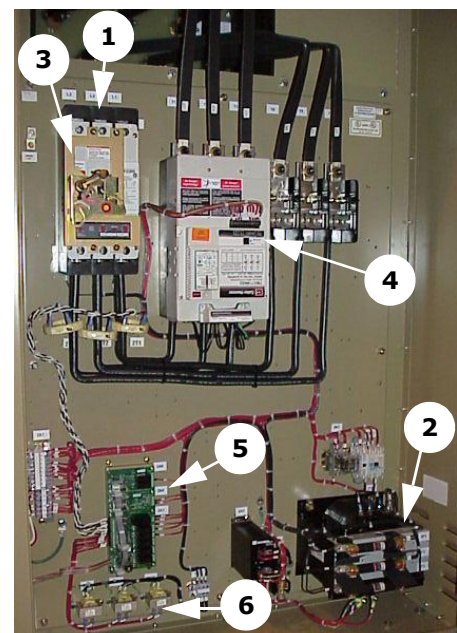

Unit-Mounted Low-Voltage Adaptive Frequency Drive

The Trane Adaptive Frequency Drive AFD is a refrigerant-cooled, microprocessor controlled design. The AFD is used in lieu of a constant-speed starter and is currently available for use with 460 /480 volts 60 Hz or 380-415 volts 50Hz line power only. Adaptive Frequency is a trademarked term for the Trane® variable-speed drive, using proprietary control logic and made to Trane specifications.

About the Trane AFD

The AFD is unit-mounted and ships completely assembled, wired, and tested from the factory. The AFD controller is designed to interface with the chiller controller. It adapts to the operating ranges and specific characteristics of the chiller. The optimum chiller efficiency is created by coordinating the compressor-motor speed with the compressor inlet guide vanes. The chiller controller and the AFD controller work together to maintain the chilled-water setpoint and avoid instability regions like low level surge. If low level surge is detected, the chiller controller's surge-avoidance logic in the chiller controller makes the proper adjustments to move the operating point away from surge. The reason it is desirable to operate safely near the instability region is because this is where efficiency is maximized.

How it Works

The frequency drive regulates output voltage in proportion to output frequency to maintain ideal motor flux and constant torque-producing capability. Or put simply, a variable-speed drive controls load-side frequency and voltage to adjust the compressor motor speed. The AFD is a voltage source, pulse-width modulated (PWM) design. It consists of three primary power sections as shown in [Figure 9](#): the active rectifier, the DC bus, and the inverter.

Figure 9. AFD power sections

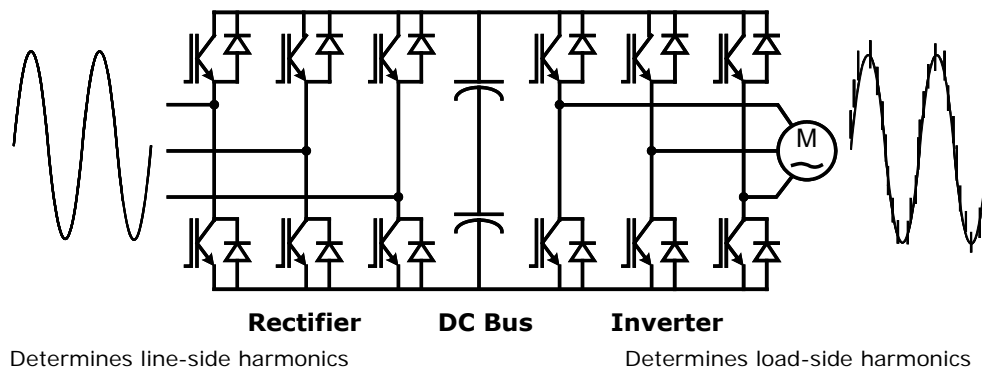

Rectifier (active). The rectifier (active) takes incoming AC power, filters it with an LCL filter (not shown), and then converts it to a fixed DC voltage. The insulated-gate bipolar transistor (IGBT) active rectifier significantly reduces the amount of line-side harmonic levels and the amount of ripple on the DC bus. No additional line side filters are required to meet IEEE harmonic requirements. This also simplifies the installation and avoids the optional filter efficiency losses. The active rectifier also has some traditional post-generation filtering capabilities to further smooth out remaining line-side harmonics.

DC bus. Capacitors store the DC power provided by the rectifier until it is needed by the inverter.

Inverter. Converts the DC voltage into a synthesized AC output voltage. This synthesized output controls both the voltage and the frequency. The synthesized output waveform consists of a series of pulses, hence the "pulse" in PWM.

Starting Sequence

Trane AFDs are programmed to start the compressor motor using low frequency and low voltage, thereby minimizing the inrush current. The motor is then brought up to speed by gradually increasing both frequency and voltage at the same time. Thus, current and torque are much lower during startup and motor acceleration than the high current, high torque associated with across-the-line or even reduced-voltage starters.

Patented Adaptive Control

A fourth element of AFD design is the microprocessor control logic which is the intelligence for the power section. It also includes all feedback sensors required for stability in the system and any required shutdown due to a fault.

The combination of speed control and inlet guide-vane (IGV) position is optimized mathematically and controlled simultaneously. The microprocessor performance allows the chiller to operate longer at higher efficiencies and with greater stability.

Features

The standard design features for the AFD include:

- NEMA 1, ventilated enclosure with a hinged door, tested to a short circuit current rating (SCCR) of 65,000 amps.
- Padlock-able, door-mounted circuit breaker/shunt trip with an Ampere Interrupting Rating (AIC) rating of 65,000 amps.
- UL/CUL listed as a package.
- Simple, modular construction.
- 460/480/60/3 or 380-415 /60/50Hz input power ± 10 percent, with drive overload capability of 100 percent continuous to 150 percent for five seconds.
- Active input rectifier will regulate to a displacement power factor of 0.98 or better at full load and a value of 0.96 at part loads.
- Full motor voltage is applied regardless of the input voltage.
- Motor thermal overload protection 102 percent continuous, 108 percent for 60 seconds, 140 percent for 1.5 seconds.
- Minimum efficiency of 97 percent at rated load and 60 hertz.
- Soft-start, controlled acceleration, coast-to-stop.
- Adjustable frequency from 38 to 60 hertz.
- Control circuit voltages physically and electrically isolated from power circuit voltage.
- 150 percent instantaneous torque available for improved surge control.
- Output line-to-line and line-to-ground short-circuit protection.
- Ground fault protection (UL-listed).

Option

AFD enclosure short circuit current rating SCCR and AIC rating of 100,000 amps available.

Unit Options

Unit-Mounted Low-Voltage Adaptive Frequency Drive

Figure 10. Trane AFD

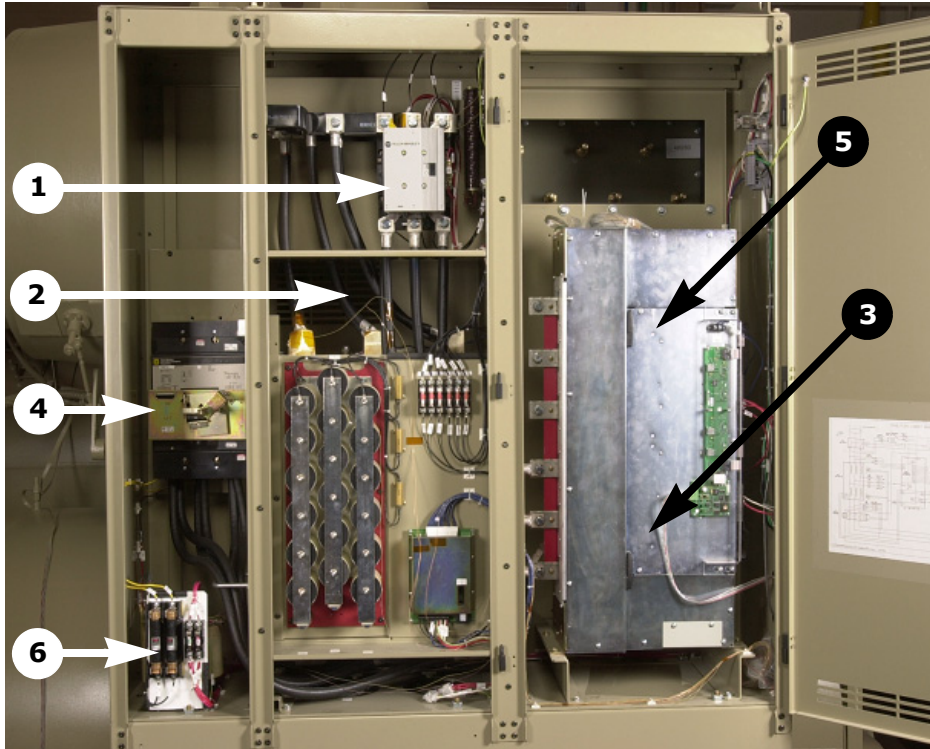

1. Pre-charge contactor
2. Inductor (behind the panel)
3. Adjustable-speed drive (inverter)
4. Circuit breaker (standard)
5. Active rectifier
6. 3 kVA control-power transformer

Environmental Specification

- 32°F to 104°F (0°C to 40°C) operating ambient temperature
- Altitude to 3,300 feet (1,000 m), amperage derate of 1 percent per every 300 feet above 3,300 feet
- Humidity, 95 percent non-condensing

Digital Data Display

The following points are digitally displayed at the chiller controller:

- Output speed in hertz
- Output speed in rpm
- Input frequency
- Input/output line voltage
- Input/output kW
- Input/output current
- Average output current in percent RLA
- Load-side power factor
- AFD transistor temperature
- Fault

Harmonics

Harmonics has become a frequently used term in the power quality arena. Of all the power quality issues encountered today, harmonics is the least understood and most feared; unfortunately, this has resulted in overstating the impact of harmonics. Harmonics is not a “thing” but a way to define current or voltage distortion on a power line. Harmonics can be directly linked to nonlinear loading of a power system. Nonlinear loads are created by devices connected to a given power system that

draw current from the power source with a waveform that is not a pure sine wave. All nonlinear loads, including variable-frequency drives, will create current and voltage distortion. Typically, harmonics is not an insurmountable issue when applying an AFD on a centrifugal chiller.

Harmonic Attenuation

Harmonic attenuation is standard on the unit-mounted refrigerant-cooled AFDs and includes an integrated active rectification control system. This system results in less than 5 percent current total demand distortion (TDD) as measured at the AFD. The AFD meets the IEEE 519 standard for less than 5 percent TDD.

IEEE 519

It is important to recognize that IEEE 519 as a guideline relates to the entire system, not specifically to any one load or product. IEEE 519 establishes requirements at the point of common coupling (PCC) where the building connects to the utility system. The standard contains no specific requirements for the internal electrical loads. Even though Trane AFD-equipped chillers will attenuate their own harmonics, other nonlinear loads on the same system could still create harmonic problems. In buildings where harmonics might be a concern, Trane recommends conducting a power-distribution system analysis to determine if there is a need to further attenuate harmonics at the system level.

Application of Drives on Chillers

Certain system characteristics favor installation of an AFD because of energy cost savings and shorter payback. These systems include:

- Condenser water temperature relief (colder than design temperatures)
- Chilled-water reset
- Utilities with high kWh and low kW demand rates

Condenser Water Temperature Relief or Chilled-Water Reset

Compressor lift reduction is required for a AFD chiller application, both to provide stable chiller operation and to achieve greater energy savings. Lift said another way is called relief and assumes colder condenser inlet temperatures over the design entering temperature. Intelligent control to reduce condenser water temperature, or chilled-water reset strategies, are key to AFD savings in chiller system applications. Many believe that AFDs offer better efficiency at part load. The reason this belief exists is because when people review part load data it typically has been run with condenser relief. An AFD can incrementally improve efficiency over a constant speed chiller at any load if you have substantial hours reduced entering condenser temperatures.

High Operating Hours with Relief

[Figure 11, p. 26](#) is based on a 800-ton chiller at 42°F/55°F in the evaporator, and 85°F entering condenser water temperature, and 2.5 gpm/ton of flow. Three lines are plotted (ECWT at 85°F, 75°F, and 65°F); the y-axis is kW/ton and the x-axis is chiller percent load.

First, note the unloading curve with the 85°F entering condenser water—this would be considered unloading with no relief. Then compare this curve with next two curves showing unloading with relief at 75°F and 65°F, respectively. Note that efficiency improves significantly independent of the chiller load. This is why AFDs are applied when there are significant hours of operation during which the condensing temperature is reduced.

Unit Options

Unit-Mounted Low-Voltage Adaptive Frequency Drive

Figure 11. Unloading curves with AFD chiller and 85°F, 75°F, 65°F ECWT temps

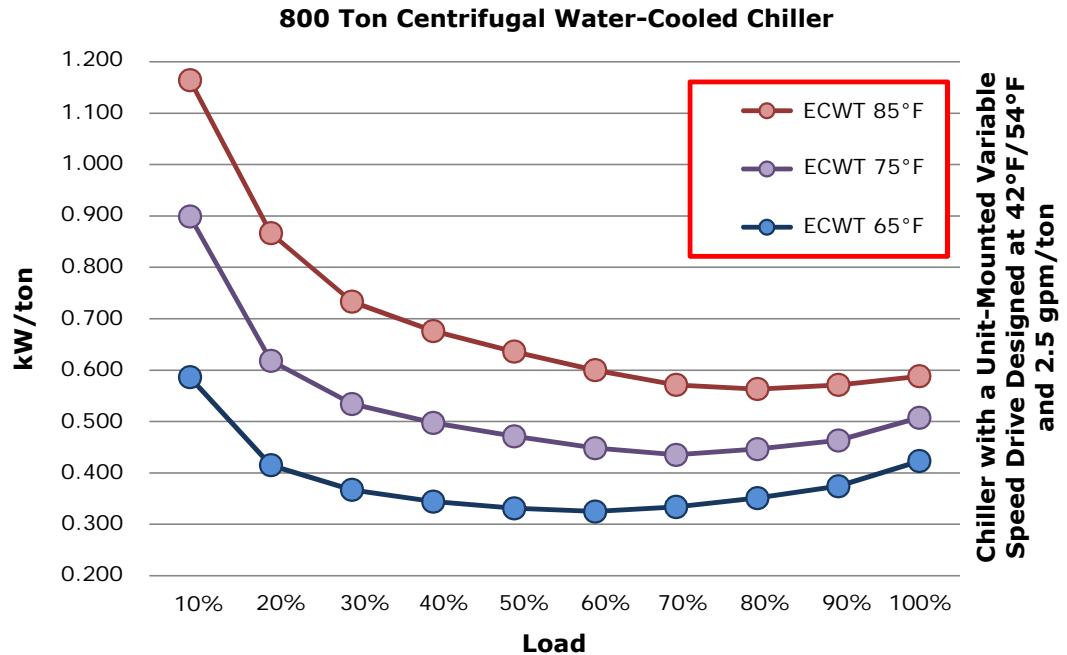

High kW Demand Charges

Electric utility bills normally include both peak-based and consumption-based energy components. The demand or distribution charges are still significant portions of the energy bill, even in deregulated markets. These charges are established by usage during utility peak hours, by individual peak usage, or a combination of peak and individual usage. This portion may or may not be influenced by installation of an AFD, because an AFD-equipped chiller draws more power at full load. If the peak chiller load coincides with utility peak hours, then the peak-based portion of the energy bill will increase. The energy or kWh portion will almost certainly be reduced because of the improved efficiency of the chiller plant during part-load and part-lift conditions throughout the year.

The greater the kWh charge, and the smaller demand or distribution charges, the shorter the payback.

Unit-Mounted AMPGARD Medium-Voltage Starters

The AMPGARD® medium-voltage starter family by Eaton Cutler-Hammer®, built to Trane specifications, is available as a factory-installed option for use with CenTraVac chillers. Trane mounts, wires, and tests 2,300–6,600 volt starters at the factory, so you don't have to. This reduces, or eliminates altogether, the time, expense, and any added risk associated with having the starter installed and wired at the job site.

AMPGARD reduces starter size to nearly half

Medium-voltage starters have traditionally been freestanding due to their large size and weight. Not until recent advances in contactor technology and component layout have medium-voltage starters been small enough to make unit-mounting feasible. This way, the starter becomes an integral part of the chiller, saving on equipment floor space.

Across-the-Line (Full Voltage)

An across-the-line starter is the smallest medium-voltage starter option. These starters draw the highest inrush current at startup (100 percent of LRA), and have the shortest acceleration time (3–5 seconds).

Primary Reactor

Primary reactor type starters have an inrush current draw of 65 percent of LRA at startup. Their acceleration time (3–8 seconds) is slightly higher than an across-the-line starter.

Autotransformer

Autotransformer starters have the lowest inrush current draw of 45 percent of LRA at startup. They have an acceleration time of 3–8 seconds.

Standard Features

- UL approved
- Factory installed (unit-mounted only)
- Non-load-break isolation switch and current limiting fuses
- NEMA Class E2 fused interrupting ratings
 - 200 MVA @3000 V
 - 400 MVA @4600 V
 - 750 MVA @6600 V
- Voltage range of 2,300–6,600 volts
- Types: Across-the-line (full voltage), primary reactor, autotransformer
- Phase voltage sensors for kW, volts/phase protection, under/overvoltage
- Eaton Cutler-Hammer AMPGARD, designed and built to Trane specifications

Optional Features

- IQ150 and IQDP 4130 electrical metering packages
- Ground fault protection
- Factory-installed power factor correction capacitors sized specific to the motor, factory-wired and mounted inside the starter

Unit Options

Unit-Mounted AMPGARD Medium-Voltage Starters

Figure 12. Unit-mounted medium-voltage primary reactor or autotransformer

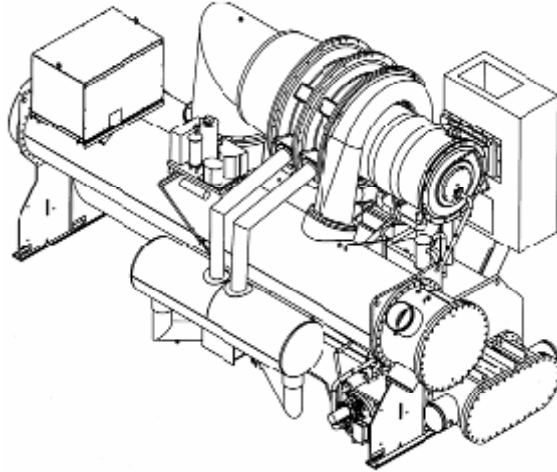

Figure 13. Reduced-voltage section of a unit-mounted starter



Starter by Others

If CenTraVac starting equipment is provided by others, the starter must be designed in accordance with the current Trane standard engineering specification "Water-Cooled CenTraVac Starter Specification." It is also recommended that two copies of the interconnecting and control circuit wiring diagrams be forwarded to Trane for review. This service is provided at no charge, and is intended to help minimize the possibility that Trane CenTraVac chillers will be applied in improper starting and control systems. However, the responsibility for providing proper starting and control systems remains with the system designer and the installer.

Enhanced Electrical Protection Package Options

Customers who purchase the Enhanced Electrical Protection Package have additional electrical options. These options can be applied to remote-mounted medium-voltage starters, both from Trane and other starter manufacturers.

CPTR, Control Power Transformer (Enhanced Electrical Protection Package option) on Low- and Medium-Voltage Starters

Unit-mounted, factory-wired, separate enclosure mounted next to the control panel with:

- Flanged disconnect
- Secondary fuse status indicator (blown or not-blown)
- Fused primary and secondary power
- UL 508 Type 12 construction
- 4 kVA control power transformer (480 to 115 volts)

SMP, Supplemental Motor Protection (Enhanced Electrical Protection Package option) on Medium-Voltage Starters Only

Unit-mounted, factory-wired, separate enclosure mounted to the motor with:

- Surge capacitors
- Field-accessible terminal block for trouble-shooting via panel
- Lightning arrestors
- Zero-sequence ground fault
- UL 347 tested Type 12 construction

DMP, Differential Motor Protection (SMP option) on Medium-Voltage Starters Only

DMP replaces the zero-sequence ground fault protection. Instead, it uses a flux-summation self-compensating differential protection scheme for more quickly and more precisely removing line power during a fault.

Note: DMP is available only for 1062 kW and larger motor sizes up to 5000 volts.

CVAC, Customer-Supplied Vacuum Circuit Breaker on Medium-Voltage Starters Only

- Three-pole disconnect
- Relays for vacuum circuit-breaker starter type
- Industrial terminal block
- Secondary 120 to 30 volt PTs (for medium-voltage units)

Free Cooling Allows Reduced Operating Costs

Consider a CenTraVac chiller option that can provide up to 45 percent of the nominal chiller capacity—without operating the compressor. Think of the significant energy and cost savings possible in many applications. This option is available on most Trane® chillers, factory-installed.

Free cooling operation is based on the principle that refrigerant migrates to the area of lowest temperature. When condenser water is available at temperatures lower than the required leaving chilled-water temperature, typically 50°F to 55°F (10°C to 12.8°C), the unit control panel starts the free cooling cycle automatically.

Figure 14. Free cooling schematic

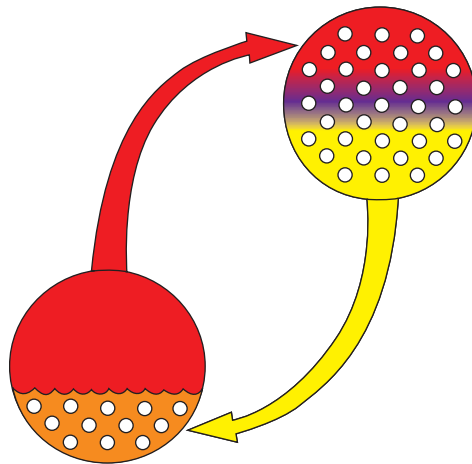

When the free cooling cycle can no longer provide sufficient capacity to meet cooling requirements, mechanical cooling is restarted automatically by the unit control panel.

For example, a building with a high internal cooling load is located in a climate with cold winters. It is possible to cool the building exclusively with free cooling three to six months of the year! Free cooling payback can easily be less than a year.

Free cooling is factory installed and requires no additional floor space or piping than the standard CenTraVac chiller (unlike plate-frame heat exchangers).

Benefits

The Trane® patented free cooling accessory for Trane CenTraVac chillers adapts the basic chiller so it may function as a simple heat exchanger using refrigerant as the working fluid. When condenser water is available at temperatures lower than the desired chilled liquid temperature, free cooling can provide up to 45 percent of nominal chiller capacity without operation of the compressor. This feature may result in substantial energy cost savings on many installations.

Reliability

Two simple valves are the only moving parts.

Single-Source Responsibility

Free cooling is Trane-engineered, -manufactured, and -installed.

Ease of Operation

Changeover on free cooling by single switch control.

Ease of Installation

Completely factory-installed and leak-tested components. All valve operators and controls are factory wired.

Application

Modern buildings often require some form of year-round cooling to handle interior zones, solar loads, or computer loads. As the outside air temperature decreases below the inside air design temperature, it is often possible to use an outside air economizer to satisfy the cooling requirements. There are a number of instances, however, where CenTraVac free cooling offers a number of advantages over the use of an outside air economizer. It is possible for the free cooling chiller to satisfy the cooling load for many hours, days, or months during the fall, winter, or spring seasons without operation of the compressor motor. This method of satisfying the cooling requirement can result in significant total energy savings over other types of systems. The savings available are most easily determined through the use of a computer energy analysis and economic program, such as TRACE™ (Trane Air Conditioning and Economics).

The suitability of free cooling for any particular installation depends upon a number of factors. The availability of low temperature condensing water, the quality of the outside air, the type of airside system, the temperature and humidity control requirements, and the cost of electricity all have a direct impact on the decision to use a free cooling chiller.

The use of CenTraVac free cooling depends on the availability of cold condenser water from a cooling tower, river, lake, or pond. As a general rule of thumb, locations which have a substantial number of days with ambient temperatures below 45°F (7.2°C) wet bulb or more than 4000 degree-days per year are well suited to free cooling operation. A cooling tower must be winterized for off-season operation and the minimum sump temperature is limited by some cooling tower manufacturers. Cooling tower manufacturers should be consulted for recommendations on low temperature operation. With river, lake, or pond supply, condenser water temperatures down to freezing levels are possible. Areas which have fouled air may be more conducive to free cooling operation than the use of an outside air economizer.

Airside systems which both heat and cool the air can often effectively use a free cooling chiller. Dual-duct, multizone, and reheat systems fall into this general category. As the outside temperature begins to fall, the cool outside air satisfies the cooling requirements (through an outside air economizer). As the outdoor air temperature becomes very low, the outdoor air may need to be heated in order to maintain the design supply air temperature when it is mixed with return air. This “heating penalty” can be eliminated by using CenTraVac free cooling. Warm chilled-water temperatures provided by the free cooling chiller would allow a warmer air temperature off the chilled-water coils, eliminating the heating energy required by using only an outside air economizer. With high cost electricity in most areas of the country, this heating penalty can be very significant.

Temperature and humidity control requirements are important considerations when evaluating the use of CenTraVac free cooling. Low temperature outside air (from the outside air economizer) often requires a large amount of energy for humidification purposes. Free cooling operation helps to reduce these humidification costs on many applications.

It is important to note that those applications which require extremely precise humidity control typically cannot tolerate warmer than design chilled-water temperatures. Therefore, since free cooling chillers normally deliver warmer than design chilled water temperatures, free cooling operation is usually not applicable with systems which require precise humidity control.

Free cooling is not used in conjunction with heat recovery systems, since mechanical cooling must be used to recover heat that will be used elsewhere in the building for simultaneous heating.

Operation

Free cooling operates on the principle that refrigerant flows to the area of lowest temperature in the system. The Tracer system/Chiller Plant Manager (CPM) can be used for automatic free cooling control. When condenser water is available at a temperature lower than the required leaving



Unit Options

Free Cooling Allows Reduced Operating Costs

chilled-water temperature, the CPM starts the free cooling cycle. If the load cannot be satisfied with free cooling, the CPM or a customer-supplied system can automatically switch to the powered cooling mode. If desired, the chiller can be manually switched to the free cooling mode at the unit control panel. Upon changeover to free cooling, the shutoff valves in the liquid and gas lines are opened and a lockout circuit prevents compressor energization. Liquid refrigerant drains from the storage tank into the evaporator, flooding the tube bundle. Since the refrigerant temperature and pressure are higher in the evaporator than in the condenser, due to the water temperature difference, the refrigerant gas boiled off in the evaporator will flow to the condenser. The gas then condenses and flows by gravity back to the evaporator. This automatic refrigeration cycle is sustained as long as a temperature difference exists between the condenser water and evaporator water.

The difference in temperature between the condenser and evaporator determines the rate of refrigerant flow between the two shells and hence the free cooling capacity.

If the system load becomes greater than the free cooling capacity either the operator manually stops free cooling, a binary input from a customer-supplied system disables free cooling, or the CPM can automatically perform this function. The gas and liquid valves close and the compressor starts. Refrigerant gas is drawn out of the evaporator by the compressor, compressed, and introduced into the condenser. Most of the condensed liquid first takes the path of least resistance by flowing into the storage tank which is vented to the high pressure economizer sump by a small bleed line. When the storage tank is filled, liquid refrigerant must flow through the bleed line restriction. The pressure drop through the bleed line is greater than that associated with the orifice flow control device, hence liquid refrigerant flows normally from the condenser through the orifice system and into the economizer.

The free cooling option consists of the following factory-installed or supplied components:

- Additional refrigerant charge required for the free cooling cycle
- Manual free cooling controls on the unit control panel
- A refrigerant gas line, including an electrically actuated shutoff valve, installed between the evaporator and condenser
- A liquid-refrigerant storage vessel adjacent to the economizer
- A valved-liquid return line, including an electrically activated shutoff valve, between the condenser sump and evaporator

For specific information on free cooling applications, contact your local Trane sales office.

Figure 15. Compressor operation schematic

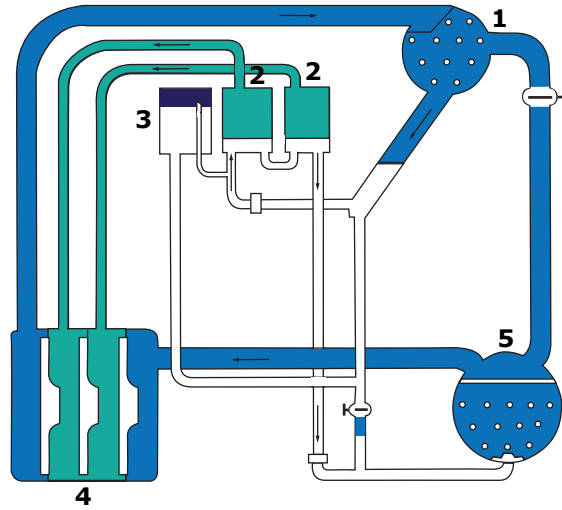

1. Condenser
2. Economizer
3. Refrigerant Storage Tank
4. Compressor
5. Evaporator

Figure 16. Free cooling operation schematic

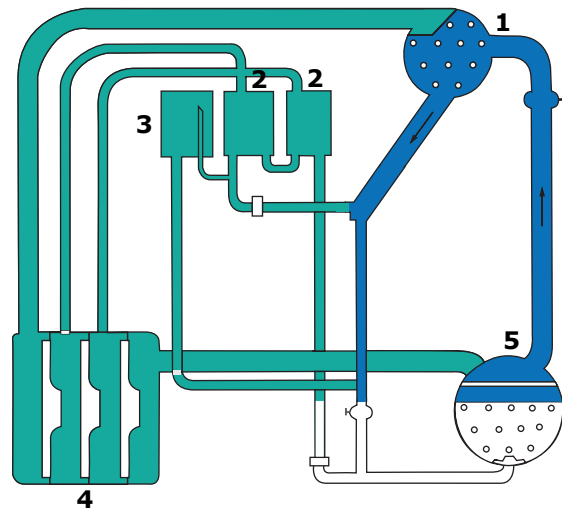

1. Condenser
2. Economizer
3. Refrigerant Storage Tank
4. Compressor
5. Evaporator

System Options

Heat Recovery

Use of the Heat Recovery CenTraVac can significantly reduce the energy operating costs of many buildings by using heat which normally would be rejected to the atmosphere. Typical uses for this heat are perimeter zone heating, reheat air conditioning systems, and preheating domestic hot water. Any building with a simultaneous heating and cooling load is a potential candidate.

Most heating applications require water temperatures higher than the 85°F to 95°F (29.4°C to 35°C) typically sent to the cooling tower. Therefore, most heat recovery chillers are required to produce higher leaving condenser water temperatures, and thus will not duplicate the energy efficiencies of cooling-only machines. Figure 17 illustrates the typical operating cycles of a cooling-only machine and a heat recovery machine.

The most noticeable differences are:

1. The pressure differential provided by the compressor is much greater for the heat recovery cycle.
2. The amount of heat rejected from the heat recovery condenser is greater than that which would be rejected in cooling-only operation.
3. There is a decrease in the refrigeration effect (RE). Higher condensing pressures increase the intermediate pressure in the economizer. Therefore, the liquid in the economizer has a higher enthalpy during the heat recovery mode than during standard chiller operation and the refrigeration effect is slightly decreased. Because of this decreased refrigeration effect, the compressor must pump more gas per ton of refrigeration.

Figure 17. Typical operating cycles

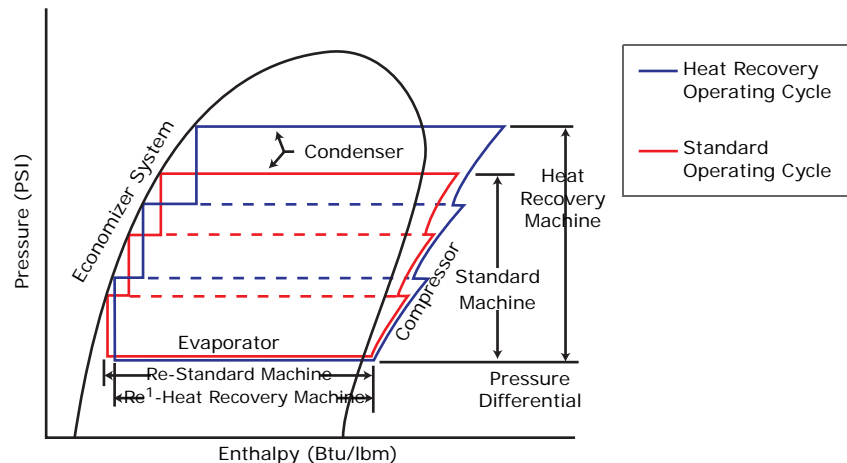

The effect of this increased pressure differential and decreased refrigeration effect is a heat recovery machine which has a higher kW/ton energy consumption during heat recovery operation.

Typical catalog kW/ton for heat recovery machines operating in the heat recovery mode range from 0.64 to 0.84 kW/ton compared to a range of 0.54 to 0.57 kW/ton for a cooling-only machine. Not only can there be an energy consumption penalty paid due to the inherent differences in operating cycles for heat recovery machines, but traditional machine design can add to that energy handicap. A heat recovery machine's operating efficiency is penalized year-round by having the capability to produce high heating water temperatures. Impellers are selected to produce the maximum required refrigerant pressure difference between the evaporator and condenser, which is shown in Figure 18. This means the impeller diameters are determined by the heat recovery operating conditions.

The multistage compressor and advanced impeller design on the CenTraVac chiller reduce this costly energy penalty. The higher lift and stability the multistage compressor allows a closer match of impeller size for both the cooling only and heat recovery operating conditions. In addition, the computer designed impellers and crossover are designed to reduce losses as the kinetic energy of the refrigerant gas is converted to static pressure.

Simultaneous Heating and Cooling

The Trane Heat Recovery CenTraVac chiller is an excellent choice for applications requiring simultaneous heating and cooling. CenTraVac models save energy by recovering heat normally rejected to the atmosphere and putting that energy to use by providing space heating, building hot water, or process hot water.

Figure 18. Refrigerant pressure difference

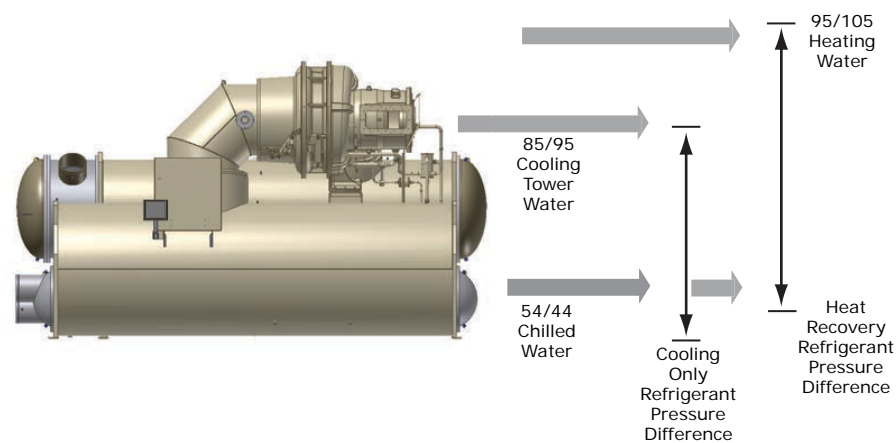

This heat is provided at a fraction of conventional heating systems cost. A heat recovery CenTraVac can provide 95°F to 120°F (35°C to 48.9°C) hot water depending upon the operating conditions. Two separate condenser shells are used with the Heat Recovery CenTraVac chiller. The heating circuit and cooling tower circuit are separate, preventing cross contamination. Refrigerant gas from the compressor flows into both condenser shells allowing heat rejection to one or both condenser water circuits.

The reliability of the Heat Recovery CenTraVac chiller has been proven in installations around the world. This option is completely factory packaged.

To further reduce the system energy requirements, the following design considerations should be incorporated into any heat recovery system.

Heating Water Temperatures and Control

It is always desirable to use as low a heating water temperature as the application allows. Experience has shown that a design heating water temperature of 105°F to 110°F (40.5°C to 43.3°C) can satisfy most heating requirements. Lower heating water temperatures increase the chiller operating efficiency both in the heating mode and in the cooling mode. In general, the heat recovery power consumption will increase 7 percent to 14 percent for every 10°F (-12.2°C) increase in the design heating water temperature. A consideration which is just as important as the design heating water temperature is how that temperature is controlled. In most cases, the heating water temperature control should be designed to maintain the return heating water temperature. By allowing the supply water temperature to float, the mean water temperature in the system drops as the chiller load decreases and less heat is rejected to the condenser. As the mean heating water temperature drops, so does the refrigerant condensing temperature and pressure difference which the compressor is required to produce at part load. This increases the unloading range of the compressor.

System Options

Heat Recovery

When the supply heating water temperature to the building system is maintained and the return heating water temperature to the condenser is allowed to float, the mean heating water temperature actually rises as the chiller load decreases and less heat is rejected to the condenser. As [Figure 19](#) illustrates, when the compressor unloads, the pressure difference that it must oppose to prevent surging remains essentially the same, while the compressors capability to handle the pressure difference decreases. Therefore, the chiller's capability to unload without the use of hot gas bypass is reduced.

Figure 19. Heating water control

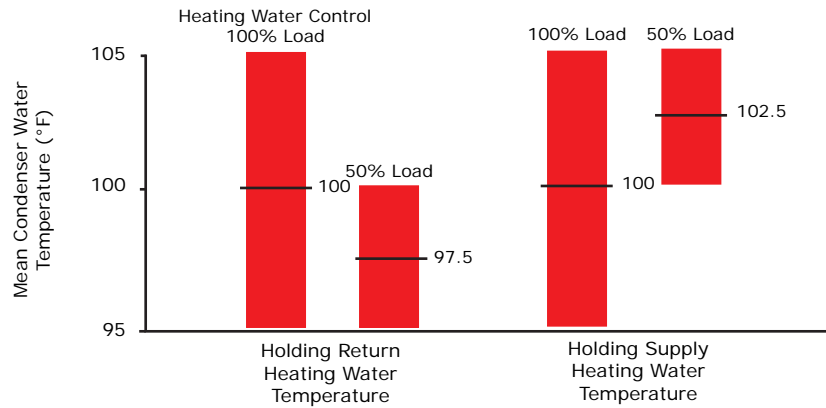

Hot gas bypass artificially increases the load on the compressor by diverting refrigerant gas from the condenser back to the compressor. Although hot gas bypass increases the units power consumption by forcing the compressor to pump more refrigerant gas, it will increase the heat available to recover for those applications where significant heating loads remain as the cooling load decreases.

Auxiliary Condenser for Economical Heat Recovery

The Trane® auxiliary condenser provides economical heat recovery for applications with small heating demand. The Trane® auxiliary condenser option consists of a separate condenser connected in parallel with the standard condenser to provide simple heat recovery capability for applications where full heat recovery or high heating water temperatures are not required. Decreased life cycle operating costs result through use of the auxiliary condenser option because waste heat, which normally would be rejected by the cooling tower circuit, is now used for building heating requirements.

Figure 20. Auxiliary condenser option

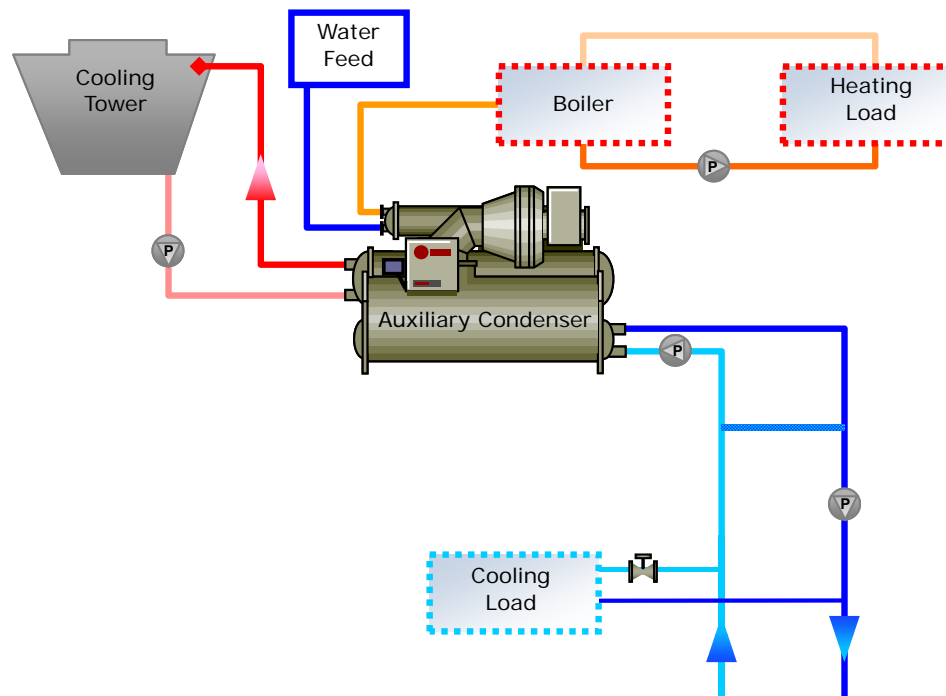

Application

A simultaneous demand for heating and cooling is necessary to apply any heat recovery system. Typical uses for this water include domestic water preheat, boiler makeup water preheat, and reheat air conditioning systems and swimming pools. This is opposed to traditional heat recovery applications where higher temperature water is used to satisfy a building heating load, provide full heat input for domestic hot water, or provide the typically larger flow rates of hot water for process applications. Building use is not limited to the traditional heat recovery candidates. Schools, hospitals, office buildings, and hotels have all proved to be excellent applications for the auxiliary condenser option.

Increased Chiller Efficiency

The auxiliary condenser not only captures energy otherwise lost, it also increases chiller efficiency by increasing condenser heat transfer surface area and lowering the pressure differential the compressor must generate. This is because the auxiliary condenser water is always at a lower temperature than the standard condenser water.

Auxiliary condensers are available in standard and large. Because the auxiliary condenser is a separate condenser, there is no cross contamination between the cooling tower water and the heat recovery water circuits.



System Options

Auxiliary Condenser for Economical Heat Recovery

No temperature controls are required and auxiliary condensers come factory-mounted.

Controls

The auxiliary condenser was designed for simplicity of operation. Machine load, water flow rate, and temperature determine the amount of heat recovered. There are no controls needed for heating water temperature because no attempt is made to maintain a specific hot water temperature in or out of the auxiliary condenser.

Operation

The auxiliary condenser is a factory-mounted, separate, shell and tube heat exchanger available on water-cooled CenTraVac chillers.

Because refrigerant gas always migrates to the area of lowest temperature, auxiliary condenser operation is simple. As the discharge gas leaves the compressor, it is free to flow to the auxiliary condenser or the standard condenser. Since water entering the auxiliary condenser is normally colder than that entering the standard condenser, the auxiliary condenser will have a lower bundle temperature and will attract the refrigerant gas. The auxiliary condenser will recover as much heat as the machine cooling load, heating water temperature, and flow rate will allow. All remaining heat will automatically be rejected through the standard condenser to the atmosphere through the cooling tower. No controls are needed to balance heat rejection in the two condensers.

Good system design will include a heated water bypass to ensure that water does not circulate through the auxiliary condenser when the chiller is de-energized. There are several ways to bypass the auxiliary condenser. When the hot water system is installed as shown, the bypass is automatic if the heating water pump is interlocked with the chiller compressor motor.

Another bypass arrangement is to install a diverting valve. When interlocked with the compressor motor, this valve diverts the heating water flow to the conventional heating system whenever the chiller is not operating. These are only examples of the many ways available to accomplish a bypass.

Contact your local Trane sales office for further specific information.

Figure 21. Auxiliary condenser flow limits and connection sizes

Auxiliary Condenser Bundle Size	Two Pass				Connection Size (in)
	Internally Enhanced IECU		Low Fouling TLCU		
	Minimum (gpm)	Maximum (gpm)	Minimum (gpm)	Maximum (gpm)	
Standard (80)	74	276	69	194	5
Large (130)	121	453	112	318	5

Ice Storage Provides Reduced Electrical Demand

An ice storage system uses a dual-duty chiller to make ice at night when utilities charge less for electricity. The ice supplements or even replaces mechanical cooling during the day when utility rates are at their highest. This reduced need for cooling results in big utility cost savings.

Another advantage of ice storage is standby cooling capacity. If the chiller is unable to operate, one or two days of ice may still be available to provide cooling. In that time the chiller can be repaired before building occupants feel any loss of comfort.

The Trane CenTraVac chiller is uniquely suited for low temperature applications, like ice storage, because it provides multiple stages of compression. Competitive chillers provide only one stage. This allows the CenTraVac chiller to produce ice efficiently with less stress on the machine.

Simple and smart control strategies are another advantage the CenTraVac chiller has for ice storage applications. Trane Tracer building management systems can actually anticipate how much ice needs to be made at night and operate the system accordingly. The controls are integrated right into the chiller. Two wires and preprogrammed software dramatically reduce field installation cost and complex programming.

Trane® centrifugal chillers are well suited for ice production. The unique multi-stage compressor design allows the lower suction temperatures required to produce ice and the higher chiller efficiencies attributed to centrifugal chillers. Trane® three-stage and two-stage centrifugal chillers produce ice by supplying ice storage vessels with a constant supply of 22°F to 24°F (-5.6°C to -4.4°C) glycol solution. Centrifugal chillers selected for these lower leaving fluid temperatures are also selected for efficient production of chilled fluid at nominal comfort cooling conditions. The ability of Trane® chillers to serve “double duty” in ice production and comfort cooling greatly reduces the capital cost of ice storage systems.

A glycol solution is used to transfer heat from the ice storage tanks to the centrifugal chiller and from the cooling coils to either the chiller or the ice storage tanks. The use of a freeze protected solution eliminates the design time, field construction cost, large refrigerant charges, and leaks associated with ice plants. Ice is produced by circulating 20°F to 25°F (-5.6°C to -4.4°C) glycol solution through modular insulated ice storage tanks. Each tank contains a heat exchanger constructed of polyethylene tubing. Water in each tank is completely frozen with no need for agitation. The problems of ice bridging and air pumps are eliminated.

When cooling is required, ice chilled glycol solution is pumped from the ice storage tanks directly to the cooling coils. No expensive heat exchanger is required. The glycol loop is a sealed system, eliminating expensive annual chemical treatment costs. The centrifugal chiller is also available for comfort cooling duty at nominal cooling conditions and efficiencies. The modular concept of glycol ice storage systems and the proven simplicity of Trane Tracer controls allow the successful blend of reliability and energy saving performance in any ice storage application.

The ice storage system is operated in six different modes: each optimized for the utility cost of the hour.

1. Off
2. Freeze ice storage
3. Provide comfort cooling with ice
4. Provide comfort cooling with chiller
5. Provide comfort cooling with ice and chiller
6. Freeze ice storage when comfort cooling is required

System Options

Ice Storage Provides Reduced Electrical Demand

Figure 22. Ice storage demand cost savings

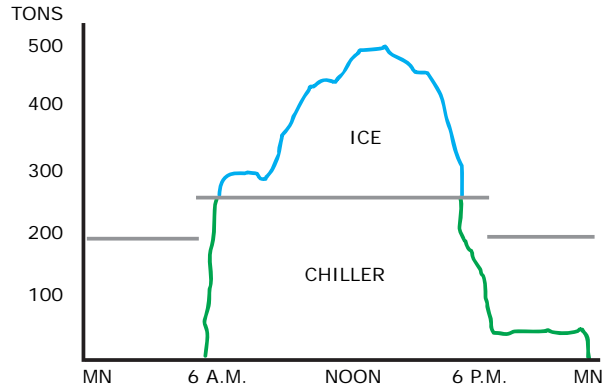

Tracer optimization software controls operation of the required equipment and accessories to easily transition from one mode of operation to another. For example: even with ice storage systems there are numerous hours when ice is neither produced or consumed, but saved. In this mode the chiller is the sole source of cooling. For example, to cool the building after all ice is produced but before high electrical demand charges take effect, Tracer sets the centrifugal chiller leaving fluid setpoint to the system's most efficient setting and starts the chiller.

When electrical demand is high, the ice pump is started and the chiller is either demand limited or shut down completely. Tracer controls have the intelligence to optimally balance the contribution of ice and chiller in meeting the cooling load.

The capacity of the chiller plant is extended by operating the chiller and ice in tandem. Tracer rations the ice, augmenting chiller capacity while reducing cooling costs.

When ice is produced, Tracer will lower the centrifugal chiller leaving fluid setpoint and start the chiller, ice pumps, and other accessories. Any incidental loads that persists while producing ice can be addressed by starting the load pump and drawing spent cooling fluid from the ice storage tanks.

For specific information on ice storage applications, contact your local Trane sales office.

Application Considerations

Condenser Water Control

Trane CenTraVac chillers start and operate over a range of load conditions with controlled water temperatures. Reducing the condenser water temperature is an effective method of lowering the chiller power input; however, the effect of lowering the condenser water temperature may cause an increase in system power consumption.

In many applications, Trane CenTraVac chillers can start and operate without control of the condenser water temperature. However, for optimum system power consumption, and for any applications with multiple chillers, control of the condenser water circuit is recommended. Integrated control of the chillers, pumps and towers is easily accomplished with the onboard Tracer chiller controller and/or Tracer Summit™ or Tracer SC system.

Most chillers are designed to entering tower temperatures around 85°F (29.5°C), but Trane CenTraVac chillers can operate at reduced lift down to a 3 psid pressure differential between the condenser and evaporator at any steady state load without oil loss, oil return, motor cooling, refrigerant hang-up, or purge problems. And this differential can equate to safe minimum entering condenser water temperatures at or below 55°F (12.8°C) dependent on a variety of factors such as load, leaving evaporator temperature and component combinations. Startup below this differential is possible as long as the 3 psid minimum pressure differential is achieved within a given amount of time. Refer to CTV-PRB006-EN (*Engineering Bulletin: Condenser Water Temperature Control for CenTraVac™ Centrifugal Chiller Systems with Tracer AdaptiView™ Controls*) for additional information.

Water Treatment

The use of untreated or improperly treated water in a chiller may result in scaling, erosion, corrosion, algae, or slime. It is recommended that the services of a qualified water treatment specialist be used to determine what treatment, if any, is advisable. Trane assumes no responsibility for the results of untreated, or improperly treated water.

Water Pumps

Avoid specifying or using 3600 rpm condenser and chilled-water pumps. Such pumps may operate with objectionable noises and vibrations. In addition, a low frequency beat may occur due to the slight difference in operating rpm between water pumps and CenTraVac motors. Where noise and vibration-free operation are important, Trane encourages the use of 1750 rpm pumps.

Water Flow

Today's technology challenges AHRI's traditional design of 3 gpm/ton through the condenser. Reduced condenser flows are a simple and effective way to reduce both first and operating costs for the entire chiller plant. This design strategy will require more effort from the chiller. But pump and tower savings will typically offset any penalty. This is especially true when the plant is partially loaded or condenser relief is available.

In new systems, the benefits can include dramatic savings with:

- Size and cost of the water pumps
- Pump energy (30 percent to 35 percent reduction)
- Size and cost for condenser lines and valves
- Size and cost of the cooling tower
- Tower fan energy (30 percent to 35 percent reduction)

Replacement chiller plants can reap even greater benefits from low flow condensers. Because the water lines and tower are already in place, reduced flows would offer a tremendous energy advantage. Theoretically, a 2 gpm/ton design applied to a system that originally used 3 gpm/ton would offer a 70 percent reduction in pump energy. At the same time, the original tower would require a nozzle change but would then be able to produce about two degrees colder condenser



Application Considerations

water than before. These two benefits would again typically offset any extra effort required by the chiller.

Contact your local Trane Sales Office for information regarding optimum condenser water temperatures and flow rates for a specific application.

Electrical Information

Minimum Circuit Ampacity

To properly size field electrical wiring, the electrical engineer or contractor needs to know the minimum circuit ampacity of the CenTraVac machine. The National Electrical Code (NEC), in Article 440.33, defines the method of calculating the minimum circuit ampacity. The minimum circuit ampacity is defined as the sum of two amperages: 125 percent of the compressor motor Rated Load Amps (RLA), plus the Full Load Amps (FLA) of all remaining loads on the same circuit. For starter to motor wiring, there are no other remaining loads. For main power supply to the starter, there is a remaining load consisting of the 4 kVA control power transformer which supplies power to the controls, the oil pump motor, oil sump heater, and the purge unit motor. Therefore, the remaining load FLA equals 4,000 VA divided by the unit design voltage.

As an example, calculate the minimum circuit ampacity of a machine that has a design RLA of 350 amps with 460 volt power:

$$\begin{aligned}\text{Minimum Circuit Ampacity} &= (125\% \times 350 \text{ Amps}) + \frac{4000 \text{ VA}}{460 \text{ V}} \\ &= 437.5 \text{ A} + 8.7 \text{ A} \\ &= 446.2 \text{ A}\end{aligned}$$

After the minimum circuit ampacity has been determined, the electrical engineer or contractor will refer to the appropriate NEC conductor sizing table to determine the exact conductors required. A typical table for 75°F (23.9°C) conductors is listed on the Trane submittal. The selection of conductors is based on a number of job site conditions (i.e., type of conductor, number of conductors, length of conductors, ambient temperature rating of conductors).

Branch-Circuit, Short-Circuit, and Ground Fault Protection

Circuit breakers and fused disconnects should be sized by the electrical engineer or contractor in strict accordance with NEC Article 440.21 and in accordance with all local codes. This protection should be for motor type loads and should not be less than 150 percent of the compressor motor rated load amps (RLA).

Additional electrical information is available in an engineering bulletin CTV-PRB004-EN (*Engineering Bulletin: Starters and Electrical Components for CenTraVac™ Chillers*).



Selection Procedure

Selection

The CenTraVac centrifugal chiller product line provides more than 200,000 individual unit selections over a capacity range of 120 through 3950 cooling tons. Chiller selections and performance data can be obtained through the use of the CenTraVac chiller selection program available in local Trane sales offices. This program can provide a list of chiller selections optimized to closely match specific project requirements. Nominal data and physical data for typical compressor-evaporator-condenser combinations are given by product family.

Performance

The CenTraVac computer selection program provides performance data for each chiller selection at the full-load design point and part-load operating points as required.

The Trane® computer selection program is certified by AHRI in accordance with AHRI Standard 550/590. To assure that the specific chiller built for your project will meet the required performance, and to ensure a more trouble-free startup, it is recommended that the chiller be performance tested on an AHRI-certified factory loop.

The CenTraVac computer selection program has the flexibility to select chillers for excessive field fouling allowances.

Fouling Factors

AHRI Standard 550/590 includes a definition of clean tube fouling. Recommended field fouling allowances have not changed on a relative basis; the standard fouling adjustment is a 0.0001 increment from 0.0000 "clean" on the evaporator and 0.00025 increment from 0.0000 "clean" on the condenser.

Chiller specifications should be developed using the most current standard fouling factors.

It should be noted that changing the number of water passes or water flow rates may significantly alter the performance of a particular chiller. To obtain the maximum benefit from the wide range of selections available, designers are encouraged to develop performance specifications and use the computer selection program to optimize their selections. This will allow the selection of the particular compressor-evaporator-condenser combination that most closely meets the job requirements. All selections are made using the computer selection program.

Unit Performance With Fluid Media Other Than Water

CenTraVac chillers can be selected with a wide variety of media other than water. Typically used media include ethylene glycol or propylene glycol either in the evaporator, condenser, or both. Chillers using media other than water are excluded from the AHRI 550/590 Certification Program, but are rated in accordance with AHRI 550/590. Trane factory performance tests are only performed with water as the cooling and heat rejection media. For fluid media other than water, contact the local Trane sales office for chiller selections and information regarding factory performance testing.

Flow Rate Limits

Flow rate limits for multiple pass combinations for evaporators and condensers are tabulated in the data section for the appropriate chiller family. For applications outside of these limits contact your local Trane office.

Roughing-in Dimensions

Dimensional drawings illustrate overall measurements of the chiller. The recommended space envelope indicates clearances required to easily service the CenTraVac chiller. A view of the unit with its support feet is superimposed on this drawing.

Selection Procedure

All catalog dimensional drawings are subject to change. Current submittal drawings should be referred to for detailed dimensional information. Contact the local Trane sales office for submittal and template information. If the unit must be disassembled in the field, refer to CVHE-SVN04E-EN (*Installation Guide: Disassembly and Reassembly Units—Water-Cooled CenTraVac™ Chillers*), or the most recent revision, for detailed information.

Evaporator and Condenser Data Tables

Evaporator and condenser data is shown in the Performance Data section. It includes minimum and maximum water flow limits and water connection sizes for all standard pass configurations and tube type. Pressure drops are calculated by the CenTraVac computer selection program.

Full-Load and Part-Load Performance

The CenTraVac chiller possesses excellent performance characteristics over its full range of operation. The multistage direct-drive compressor enables stable and efficient operation over a wide range of capacities, virtually eliminating the need for energy wasting hot gas bypass typically found on single-stage chillers.

An in-depth examination of project specific conditions and energy rate structures should be performed to appropriately evaluate total energy costs over a period of time. TRACE, the Trane energy analysis program is particularly well suited for this type of analysis, as well as for economic evaluation of equipment and system alternatives.



Local utilities may offer substantial monetary rebates for centrifugal chillers with specific operating kW ratings. Contact your local utility representative or Trane sales office for further information.

The electrical rate structure is a key component of an economic evaluation. Most power bills are constituted of a significant demand charge in addition to the usage charge. The full-load power consumption of the chiller plant is likely to set the kW peak and demand charge for the billing period. This places an increased emphasis on the need to keep the full-load consumption of the chiller plant low.

There are a number of variables that should be considered in developing an accurate chiller load profile to use for measuring how one machine compares with another machine at part load. The use of outdoor air economizers, variations in chiller sequencing, and chiller plant load optimization strategies should be considered. Decoupled, primary/secondary water loops or variable-primary flow designs are more efficient ways to control multiple chiller water plants. These control strategies result in one chiller operating at a more fully loaded condition rather than multiple chillers operating at part load, which would require more pumping energy.

AHRI Standard 550/590 provides chiller performance certification for the full-load condition and the "IPLV" (integrated part-load value) or "NPLV" (non-standard part-load value). These part-load values use a generic weighted chiller load profile and tower temperatures to simplify certification of part-load performance data for a single chiller. Although these values are not an indicator of actual energy use, they do provide a basis to meet ASHRAE 90.1 minimum efficiency requirements for both part and full load.



Performance Data

Table 3. Minimum and maximum evaporator flow rates (gpm)

Shell Size EVSZ	Bundle Size EVBS	One Pass						Two Pass						Three Pass					
		IECU/IMCU		IMC1		TECU		IECU/IMCU		IMC1		TECU		IECU/IMCU		IMC1		TECU	
		Min	Max	Min	Max	Min	Max	Min	Max	Min	Max	Min	Max	Min	Max	Min	Max	Min	Max
032S	200	155	1137	—	—	241	1325	78	568	—	—	120	662	52	379	—	—	80	442
	230	179	1312	—	—	270	1486	89	656	—	—	135	743	60	437	—	—	90	495
	250	191	1399	—	—	297	1635	95	700	—	—	149	818	64	466	—	—	99	545
032S/L	280	216	1596	219	1603	339	1866	108	798	109	801	170	933	72	532	73	534	113	622
	320	245	1814	249	1822	379	2085	123	907	124	911	190	1042	82	605	83	607	126	695
	350	269	1989	272	1998	—	—	134	995	136	999	—	—	90	663	91	666	—	—
050S/L	390	310	2273	—	—	473	2603	155	1137	—	—	237	1301	103	758	—	—	158	868
	480	370	2711	—	—	578	3179	185	1355	—	—	289	1589	123	904	—	—	193	1060
	580	447	3279	—	—	691	3801	224	1640	—	—	346	1900	149	1093	—	—	230	1267
	700	538	3979	545	3996	813	4469	269	1989	272	1998	406	2234	179	1326	182	1332	271	1490
	860	650	4809	659	4831	—	—	325	2405	329	2415	—	—	217	1603	220	1610	—	—
080S/L	740	579	4285	587	4304	—	—	290	2142	293	2152	—	—	193	1428	196	1435	—	—
	880	686	5028	—	—	959	1676	343	2514	—	—	480	2638	229	1676	—	—	320	1758
	1050	841	6165	—	—	1097	6035	420	3082	—	—	549	3018	280	2055	—	—	366	2012
	1210	978	7170	—	—	1227	6749	489	3585	—	—	614	3375	326	2390	—	—	409	2250
	1400	1135	8394	1150	8432	1411	7763	567	4197	575	4216	706	3881	378	2798	383	2811	470	2588
142M/L	890	691	5070	—	—	963	5298	346	2152	—	—	482	2649	230	1690	—	—	321	1766
	980	768	5633	—	—	1078	2649	384	2497	—	—	539	2966	256	1878	—	—	359	1977
	1080	866	6348	—	—	1200	6600	433	3082	—	—	600	3300	289	2116	—	—	400	2200
142M/L/E	1220	960	7105	973	7136	1349	7417	480	3585	487	3568	674	3709	320	2368	324	2379	450	2472
	1420	1117	8263	1132	8300	1501	8258	558	4216	566	4150	751	4129	372	2754	377	2767	500	2753
210L	1610	1229	9013	1246	9134	1470	8085	615	4507	623	4567	735	4043	410	3004	415	3045	490	2695
	1760	1380	10118	1398	10254	1642	9030	690	5059	699	5127	821	4515	460	3373	466	3418	547	3010
	1900	1525	11180	1545	11330	1824	10032	762	5590	772	5665	912	5016	508	3727	515	3777	608	3344
	2100	1619	11873	1641	12033	2010	11057	810	5937	820	6016	1005	5528	540	3958	547	4011	670	3686
250E	2280	1616	11848	—	—	2002	11011	808	5924	—	—	1001	5505	—	—	—	—	—	—
	2300	1762	12919	—	—	2174	11955	881	6460	—	—	1087	5978	587	4306	—	—	725	3985
	2480	1789	13116	—	—	2201	12105	894	6558	—	—	1100	6052	—	—	—	—	—	—
	2500	1929	14144	—	—	2394	13165	964	7072	—	—	1197	6582	643	4715	—	—	798	4388
210D	1610	1224	8975	—	—	1421	7816												
	1850	1397	10244	—	—	1680	9241												
	2100	1567	11493	—	—	1935	10643												
250D/M/X	2100	1567	11493	—	—	1943	10688												
	2300	1734	12719	—	—	2101	11556												
	2500	1899	13925	—	—	2314	12725												

Note: The minimum evaporator water velocity is 1.5 ft/s for IECU tubes and 2.0 ft/s for all other tubes. For a variable evaporator water flow system, the minimum GPM is generally not applicable at full load, and may be limited by other factors such as glycol. Confirm actual minimum and maximum flows for each selection before operating near flow boundaries. Values in this table are based on 0.025-in. wall tubes for M, L, S, and E bundles and 0.028-in. wall tubes for D, M, and X bundles.



Performance Data

Minimum and Maximum Evaporator Flow Rates

Minimum and maximum evaporator flow rates (L/s)

Shell Size Size EVSZ	Bundle Size EVBS	One Pass						Two Pass						Three Pass					
		IECU/IMCU		IMC1		TECU		IECU/IMCU		IMC1		TECU		IECU/IMCU		IMC1		TECU	
		Min	Max	Min	Max	Min	Max	Min	Max	Min	Max	Min	Max	Min	Max	Min	Max	Min	Max
032S	200	10	72	—	—	15	84	5	36	—	—	8	42	3	24	—	—	5	28
	230	11	83	—	—	17	94	6	41	—	—	9	47	4	28	—	—	6	31
	250	12	88	—	—	19	103	6	44	—	—	9	52	4	29	—	—	6	34
032S/L	280	14	101	14	101	21	118	7	50	7	51	11	59	5	34	5	34	7	39
	320	15	114	16	115	24	132	8	57	8	57	12	66	5	38	5	38	8	44
	350	17	125	17	126	—	—	8	63	9	63	—	—	6	42	6	42	—	—
050S/L	390	20	143	—	—	30	164	10	72	—	—	15	82	7	48	—	—	10	55
	480	23	171	—	—	36	201	12	85	—	—	18	100	8	57	—	—	12	67
	580	28	207	—	—	44	240	14	103	—	—	22	120	9	69	—	—	15	80
	700	34	251	34	252	51	282	17	125	17	126	26	141	11	84	11	84	17	94
	860	41	303	42	305	—	—	21	152	21	152	—	—	14	101	14	102	—	—
080S/L	740	37	270	37	271	—	—	18	135	19	136	—	—	12	90	12	90	—	—
	880	43	317	—	—	60	106	22	159	—	—	30	166	14	106	—	—	20	111
	1050	53	389	—	—	69	381	27	194	—	—	35	190	18	130	—	—	23	127
	1210	62	452	—	—	77	426	31	226	—	—	39	213	21	151	—	—	26	142
	1400	72	530	73	532	89	490	36	265	36	266	45	245	24	177	24	177	30	163
142M/L	890	44	320	—	—	61	334	22	136	—	—	30	167	15	107	—	—	20	111
	980	48	355	—	—	68	167	24	158	—	—	34	187	16	118	—	—	23	125
	1080	55	400	—	—	76	416	27	194	—	—	38	208	18	133	—	—	25	139
142M/L/E	1220	61	448	61	450	85	468	30	226	31	225	43	234	20	149	20	150	28	156
	1420	70	521	71	524	95	521	35	266	36	262	47	260	23	174	24	175	32	174
210L	1610	78	569	79	576	93	510	39	284	39	288	46	255	26	190	26	192	31	170
	1760	87	638	88	647	104	570	44	319	44	323	52	285	29	213	29	216	35	190
	1900	96	705	97	715	115	633	48	353	49	357	58	316	32	235	32	238	38	211
	2100	102	749	104	759	127	697	51	374	52	380	63	349	34	250	35	253	42	232
250E	2280	102	747	—	—	126	695	51	374	—	—	63	347	—	—	—	—	—	—
	2300	111	815	—	—	137	754	56	407	—	—	69	377	37	272	—	—	46	251
	2480	113	827	—	—	139	764	56	414	—	—	69	382	—	—	—	—	—	—
	2500	122	892	—	—	151	830	61	446	—	—	75	415	41	297	—	—	50	277
210D	1610	77	566	—	—	90	493												
	1850	88	646	—	—	106	583												
	2100	99	725	—	—	122	671												
250D/M/X	2100	99	725	—	—	123	674												
	2300	109	802	—	—	133	729												
	2500	120	878	—	—	146	803												

Note: The minimum evaporator water velocity is 0.457 ft/s for IECU tubes and 0.610 ft/s for all other tubes. For a variable evaporator water flow system, the minimum GPM is generally not applicable at full load, and may be limited by other factors such as glycol. Confirm actual minimum and maximum flows for each selection before operating near flow boundaries. Values in this table are based on 0.025-in. wall tubes for M, L, S, and E bundles and 0.028-in. wall tubes for D, M, and X bundles.

Performance Data

Minimum and Maximum Condenser Flow Rates

Table 3. Minimum and maximum condenser flow rates (gpm)

Shell Size Size CDSZ	Bundle Size CDBS	One Pass						Two Pass					
		IMCU		TECU		IECU		IMCU		TECU		IECU	
		Min	Max	Min	Max	Min	Max	Min	Max	Min	Max	Min	Max
032S	230	432	1584	417	1528	434	1592	216	792	208	764	217	796
032S/L	250	487	1785	466	1715	489	1793	243	892	233	857	245	897
	280	541	1985	521	1916	544	1995	271	993	260	958	272	997
	320	607	2226	576	2118	610	2236	304	1113	288	1059	305	1118
050S	360	689	2527	655	2403	692	2539	345	1263	328	1201	346	1269
050S/L	400	777	2848	738	2713	780	2861	388	1424	369	1357	390	1431
	450	875	3209	831	3056	879	3224	438	1604	415	1528	440	1612
	500	974	3570	927	3423	978	3586	487	1785	464	1707	489	1793
080S	500	974	3570	921	3378	978	3586	487	1785	461	1689	489	1793
	560	1088	3991	1031	3780	1093	4009	544	1995	515	1890	547	2005
080S/L	630	1220	4472	1160	4266	1225	4493	610	2236	580	2133	613	2247
	710	1367	5014	1311	4821	1374	5037	684	2507	655	2410	687	2519
	800	1537	5635	1472	5398	1544	5662	768	2818	739	2708	772	2831
142L	890	1739	6378	1667	6112	1747	6407	870	3189	833	3056	874	3204
	980	1936	7100	1854	6798	1945	7132	968	3550	927	3399	973	3566
	1080	2166	7942	2071	7595	2176	7979	1083	3971	1036	3797	1088	3989
	1220	2418	8864	2316	8492	2429	8905	1209	4432	1158	4246	1214	4453
	1420	2795	10248	2610	9571	2808	10296	1397	5124	1305	4786	1404	5148
210L/M	1610	2970	10890	2602	9541	2984	10940	1485	5445	1301	4771	1492	5470
	1760	3287	12053	2880	10560	3302	12109	1644	6027	1440	5280	1651	6055
	1900	3599	13196	3158	11578	3616	13257	1799	6598	1579	5789	1808	6629
	2100	3900	14299	3441	12617	3918	14366	1950	7150	1721	6309	1959	7183
250L	2100	3894	14279	3441	12617	3912	14345	1947	7140	1721	6309	1956	7173
	2300	4277	15683	3782	13868	4297	15756	2139	7842	1891	6934	2149	7878
	2500	4655	17067	4131	15149	4676	17146	2327	8533	2066	7574	2338	8573
210D	1610	2970	10890	2602	9541	2984	10940						
	1760	3287	12053	2880	10560	1421	12109						
	1900	3599	13196	3158	11578	1680	13257						
	2100	3900	14299	3441	12617	3918	14366						
250D/M/X	2100	3894	14279	3441	12617	3912	14345						
	2300	4277	15683	3782	13868	4297	15756						
	2500	4655	17067	4131	15149	4676	17146						

Note: The minimum condenser water velocity is 3 ft/s and the maximum is 11 ft/s and may be limited by other factors such as glycol. Confirm actual minimum and maximum flows for each selection before operating near flow boundaries. Values in this table are based on 0.028-in. wall tubes.



Performance Data

Minimum and Maximum Condenser Flow Rates

Minimum and maximum condenser flow rates (L/s)

Shell Size Size CDSZ	Bundle Size CDBS	One Pass						Two Pass					
		IMCU		TECU		IECU		IMCU		TECU		IECU	
		Min	Max	Min	Max	Min	Max	Min	Max	Min	Max	Min	Max
032S	230	27	100	26	96	27	100	14	50	13	48	14	50
	250	31	113	29	108	31	113	15	56	15	54	15	57
032S/L	280	34	125	33	121	34	126	17	63	16	60	17	63
	320	38	140	36	134	38	141	19	70	18	67	19	71
	360	43	159	41	152	44	160	22	80	21	76	22	80
050S	400	49	180	47	171	49	180	24	90	23	86	25	90
	450	55	202	52	193	55	203	28	101	26	96	28	102
	500	61	225	59	216	62	226	31	113	31	113	31	113
080S	500	61	225	58	213	62	226	31	113	29	107	31	113
	560	69	252	65	238	69	253	34	126	33	119	34	126
080S/L	630	77	282	73	269	77	283	38	141	37	135	39	142
	710	86	316	83	304	87	318	43	158	41	152	43	159
	800	97	355	93	341	97	357	48	178	47	171	49	179
142L	890	110	402	105	386	110	404	55	201	53	193	55	202
	980	122	448	117	429	123	450	61	224	58	214	61	225
	1080	137	501	131	479	137	503	68	250	65	240	69	252
	1220	152	559	146	536	153	562	76	280	73	268	77	281
	1420	176	646	165	604	177	649	88	323	82	302	89	325
210L/M	1610	187	687	164	602	188	690	94	343	82	301	94	345
	1760	207	760	182	666	208	764	104	380	91	333	104	382
	1900	227	832	199	730	228	836	114	416	100	365	114	418
	2100	246	902	217	796	247	906	123	451	109	398	124	453
250L	2100	246	901	217	796	247	905	123	450	109	398	123	452
	2300	270	989	239	875	271	994	135	495	119	437	136	497
	2500	294	1077	261	956	295	1082	147	538	130	478	147	541
210D	1610	187	687	164	602	188	690						
	1760	207	760	182	666	208	764						
	1900	227	832	199	730	228	836						
	2100	246	902	217	796	247	906						
250D/M/X	2100	246	901	217	796	247	905						
	2300	270	989	239	875	271	994						
	2500	294	1077	261	956	295	1082						

Note: The minimum condenser water velocity is 0.914 m/s and the maximum is 3.35 m/s, and may be limited by other factors such as glycol. Confirm actual minimum and maximum flows for each selection before operating near flow boundaries. Values in this table are based on 0.028-in. wall tubes.

Job Site Considerations

Supply and Motor Lead Wiring and Connections

Copper conductors should only be connected to the compressor motor due to the possibility of galvanic corrosion as a result of moisture if aluminum conductors are used. Copper conductors are recommended for supply leads in the starter panel.

Suggested starter panel line and load-side lug sizes (when lugs are provided) are noted in the starter submittals. These submitted lug sizes should be carefully reviewed for compatibility with conductor sizes specified by the electrical engineer or contractor. If they are not compatible, the electrical engineer or contractor should specify the required lug sizes for the particular application.

Ground lugs are provided in the motor terminal box and starter panel. The motor terminals are supplied with connection pads which will accommodate bus bars or standard terminal lugs (crimp type recommended). **Terminal lugs are field-supplied.** These connection pads provide additional surface area to minimize improper electrical connections. Also, a 3/8-inch bolt is provided on all connection pads for mounting the lugs. [Figure 23](#) illustrates the connection between the motor connection pads and the terminal lugs.

Figure 23. Electric connections

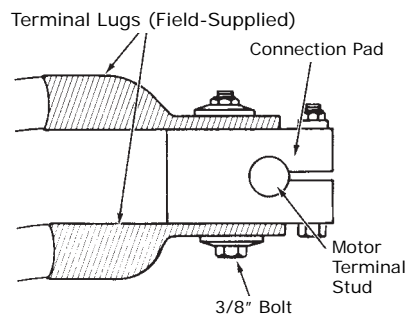

Shipment and Assembly

All CenTraVac chillers ship as a factory assembled, factory tested package, ready to rig into place on factory-supplied isolation pads. A full oil charge is shipped in the oil sump, and a 5 psig (34.5 kPa) dry nitrogen charge prevents condensation and confirms a leak-free seal before installation.

Figure 24. Shrink-wrapped unit on truck



Figure 25. Unit control panel



Each unit is shrink-wrapped to help ensure that each CenTraVac chiller is delivered to the customer with the least amount of environmental impacts as a result of shipping. The packaging process used at Trane is industry-leading: each unit is covered with a six-sided 10 mil, military-grade recyclable film.

Controls

Tracer AdaptiView Controller

Today's CenTraVac chillers offer predictive controls that anticipate and compensate for load changes. Other control strategies made possible with the Tracer AdaptiView™ controls are:

Feedforward Adaptive Control

Feedforward is an open-loop, predictive control strategy designed to anticipate and compensate for load changes. It uses evaporator entering-water temperature as an indication of load change. This allows the controller to respond faster and maintain stable leaving-water temperatures.

Soft Loading

The chiller controller uses soft loading except during manual operation. Large adjustments due to load or setpoint changes are made gradually, preventing the compressor from cycling unnecessarily. It does this by internally filtering the setpoints to avoid reaching the differential-to-stop or the current limit. Soft loading applies to the leaving chilled-water temperature and current limit setpoints.

Multi-Objective Limit Arbitration

There are many objectives that the controller must meet, but it cannot satisfy more than one objective at a time. Typically, the controller's primary objective is to maintain the evaporator leaving water temperature.

Whenever the controller senses that it can no longer meet its primary objective without triggering a protective shutdown, it focuses on the most critical secondary objective. When the secondary objective is no longer critical, the controller reverts to its primary objective.

Fast Restart

The controller allows the CenTraVac chiller to restart during the postlube process. If the chiller shuts down on a nonlatching diagnostic, the diagnostic has 30–60 seconds to clear itself and initiate a fast restart. This includes momentary power losses.

Adaptive Frequency Drive Control

The combination of speed control and inlet guide vane position is now optimized mathematically and controlled simultaneously. The increased performance of the microprocessor allows the chiller to operate longer at higher efficiency, and with greater stability.

Variable-Primary Flow (VPF)

Chilled-water systems that vary the water flow through chiller evaporators have caught the attention of engineers, contractors, building owners, and operators. Varying the water flow reduces the energy consumed by pumps, while having limited effect on the chiller energy consumption. This strategy can be a significant source of energy savings, depending on the application.

Using the optional Enhanced Flow Management Package, the Tracer chiller controller reliably accommodates variable evaporator water flow and virtually eliminates its effect on the chilled-water temperature.

Enhanced Flow Management

The Enhanced Flow Management Package is a new, optional, control feature that includes water differential-pressure-sensor transducers.

Previous controllers sometimes had difficulties with variable water flow in combination with variable-speed drives. Variable-flow compensation reacts so quickly that this energy-saving combination is now possible.

The Enhanced Flow Management Package improves the ability of the chiller to accommodate variable flow, even in combination with an Adaptive Frequency Drive (AFD). For more information on this option, refer to [“Enhanced Flow Management Package,” p. 56.](#)

34°F (1.1°C) Leaving Water Temperature

Another benefit of Feedforward Adaptive Control is the ability to operate the CenTraVac chiller at low leaving evaporator water temperatures without the use of glycol.

Colder water is generally used in wide delta-T systems, reducing the pumping energy required and making it less expensive to deliver cooling capacity over long distances. For this reason, low leaving water temperatures are frequently used in district cooling applications, but can also be used in comfort cooling applications.

Your local Trane office can assist in making chiller two- or three-pass selections using 34°F to 36°F (1.1°C to 2.2°C) leaving water temperatures. Special installation procedures may be required.

Tracer AdaptiView Control and Operator Interface

Tracer AdaptiView control comes with a unit-mounted operator interface that has a touch-sensitive 12.1-in. display. The display presents information through an intuitive navigation system using animation to provide unit status updates. Alternate languages are also available for the control panel display: the Tracer AdaptiView panel can quickly be changed to 24 different languages so that operators can understand how their chiller is performing.

Tracer AdaptiView control receives information from and communicates information to the other devices on the chiller’s communications link. Tracer AdaptiView control performs the Leaving Chilled-Water Temperature and Limit Control algorithms.

Tracer AdaptiView control can be connected to the service tool using a standard USB type B cable. The connection is located on the side of the control panel, along with a power outlet for a laptop PC power supply.



- Data graphs
- Mode overrides
- Status (all subsystems) with animated graphics
- Auto/Stop commands
- 50 diagnostics
- ASHRAE chiller log
- Setpoint adjustment (daily user points)

Tracer TU Interface

The Tracer chiller controller adds a level of sophistication better served by a PC application to improve service technician effectiveness and minimize chiller downtime. The Tracer AdaptiView control's operator interface is intended to serve only typical daily tasks. The portable PC-based service-tool software, Tracer TU, supports service and maintenance tasks.

Tracer TU serves as a common interface to all Trane® chillers, and will customize itself based on the properties of the chiller with which it is communicating. Thus, the service technician learns only one service interface.

The panel bus is easy to troubleshoot using LED sensor verification. Only the defective device is replaced. Tracer TU can communicate with individual devices or groups of devices.

All chiller status, machine configuration settings, customizable limits, and up to 100 active or historic diagnostics are displayed through the service-tool software interface.

LEDs and their respective Tracer TU indicators visually confirm the availability of each connected sensor, relay, and actuator.

Tracer TU is designed to run on a customer's laptop, connected to the Tracer AdaptiView control panel with a USB cable.

Hardware requirements for Tracer TU:

- CD-ROM
- 1024 x 768 resolution
- Microsoft® Windows® XP Pro or Windows Vista®
- An available USB port (USB 2.0)
- 1 GB RAM
- Ethernet 10/100 Lan card
- Intel® Pentium® 4 or higher processor

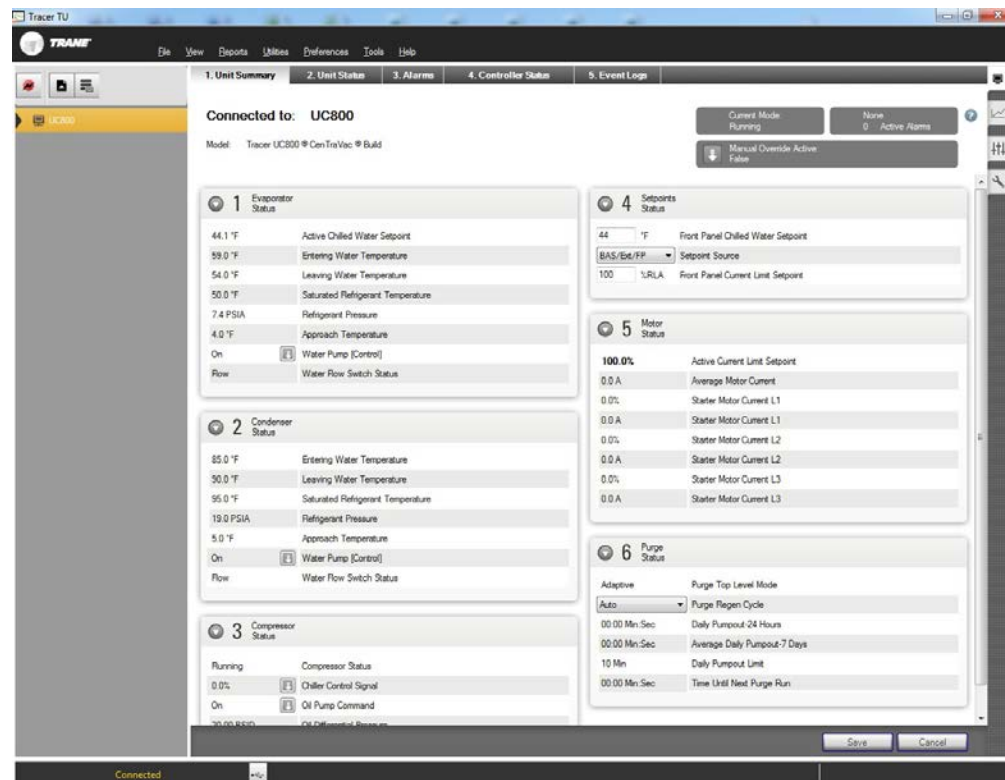

Field Connection

The field-connected items are important for turning the chiller on or off. This includes an emergency or external stop, pump relays, and verifying that flow has been established. The optional, factory-supplied flow switch or differential-pressure switch can be used to prove flow.

- Emergency stop
- Chilled-water flow contacts
- Condenser-water flow contacts
- Chilled-water pump relay
- Condenser-water pump relay
- External auto stop (enable/disable)

Heat Exchanger Control

Fundamental internal variables that are necessary to control the chiller are gathered and acted upon by the heat exchanger control function.

- Cooling only
- Heat recovery chiller

Motor Control and Compressor Protection

This includes all functions that start, run, and stop the motor. The starter module provides the interface and control of wye-delta, across-the-line, primary reactor, autotransformer, and solid-state starters. Analog and binary signals are used to interface with the solid-state starter. An AFD output signal, included in the AFD option, controls the Adaptive Frequency Drive. The motor control also provides protection to both the motor and the compressor.

EarthWise Purge Control

The purge control regulates the purge to optimize both purge and chiller efficiency. The purge controller communicates with Tracer AdaptiView control over the machine bus communications link, uploading setpoints and downloading data and diagnostics.

The purge operates if necessary when the chiller is off but still powered.

Potential/Current Transformers—3-phase

Includes factory-installed potential/current transformers in the starter for monitoring and displaying phase voltage and amperage, and provides over/undervoltage protection. Tracer AdaptiView control, Tracer TU, Tracer Summit, and Tracer SC display the following:

- Kilowatts
- Kilowatt-hours
- Power factor (uncorrected)
- Compressor-phase amperage (a, b, c)
- Compressor-phase voltage (a-b, b-c, c-a)

Chilled-Water Reset

Chilled-water reset reduces chiller energy consumption during periods of the year when heating loads are high and cooling loads are reduced. It is based on return chilled-water temperature. Resetting the chilled-water temperature reduces the amount of work that the compressor must do by increasing the evaporator refrigerant pressure. This increased evaporator pressure reduces the pressure differential the compressor must generate while in the heat recovery mode. Chilled-water reset is also used in combination with the hot-water control. By resetting the chilled-water temperature upward, the compressor can generate a higher condenser pressure, resulting in higher leaving hot-water temperatures.

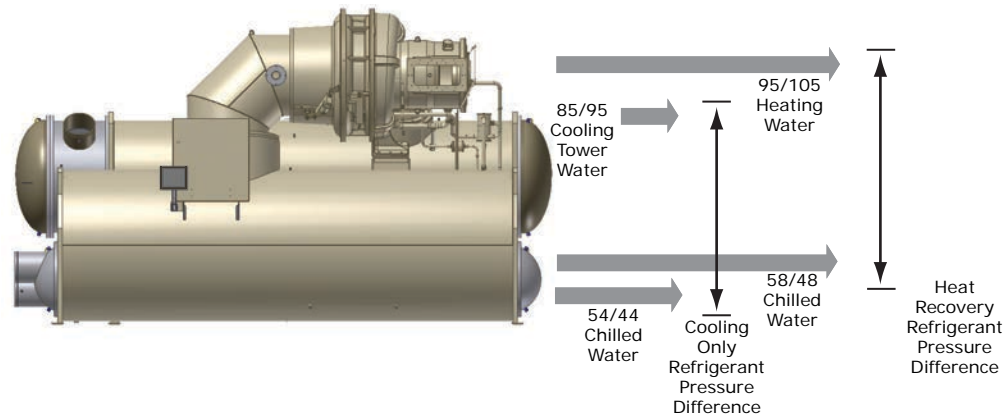
Figure 26. Chilled-water reset

Hot-Water Control

In the hot-water mode, the chiller produces hot water as its primary objective, rather than chilled water—similar to the heat recovery operation. A leaving condenser water setpoint is maintained while the leaving evaporator temperature is allowed to modulate with the load. As an option, the Extended Operation package allows an external controller to enable, disable, and modulate this mode. The hot-water mode is performed without a secondary condenser. For additional information, refer to [“Auxiliary Condenser for Economical Heat Recovery,” p. 37.](#)

Ice-Making Control

For chillers that have been selected for ice-making operation, the standard control package includes the ice-making mode. As an option, the Extended Operation package allows an external controller to enable, disable, and modulate this mode.

Extended Operation Package

Select the extended-operation package for chillers that require external ice-building control, hot water control, and/or base-loading capabilities. This package also includes a 4–20 mA or 2–10 Vdc analog input for a refrigerant monitor.

- Refrigerant monitor input
- External base-loading binary input
- External base-loading control
- External ice-building binary input
- External ice-building control
- External hot-water control binary input

Base-Loading Control

This feature allows an external controller to directly modulate the capacity of the chiller. It is typically used in applications where virtually infinite sources of evaporator load and condenser capacity are available and it is desirable to control the loading of the chiller. Two examples are industrial process applications and cogeneration plants. Industrial process applications might use this feature to impose a specific load on the facility’s electrical system. Cogeneration plants might use this feature to balance the system’s heating, cooling, and electrical generation.

All chiller safeties and Adaptive Control functions are in full effect when Base Loading is enabled. If the chiller approaches full current, the evaporator temperature drops too low, or the condenser pressure rises too high, the controller’s Adaptive Control logic limits the loading of the chiller to

prevent the chiller from shutting down on a safety limit. These limits may prevent the chiller from reaching the load requested by the Base Loading signal.

An alternative and less radical approach to Base Loading indirectly controls the chiller capacity. Artificially load the chiller by setting the chilled-water setpoint lower than it is capable of achieving. Then, modify the chillers load by adjusting the current limit setpoint. This approach provides greater safety and control stability because it leaves the chilled-water temperature-control logic in effect. The chilled-water temperature control responds more quickly to dramatic system changes and limits chiller loading prior to reaching an Adaptive Control limit.

Ice-Making Control

This feature allows an external controller to control the chiller in an ice-storage system. Ice storage is typically used in areas where high electrical demand charges can be offset by shifting building energy use to off-peak (typically nighttime) hours.

While the standard controller is fully capable of running the chiller in ice-making mode, installation savings and additional energy savings can be realized by using the Chiller Plant Control module of the Tracer building automation system. Chiller Plant Control anticipates how much ice needs to be made at night and operates the system accordingly. The controls are integrated with the chiller—two wires and pre-programmed software reduce field-installation cost and complex custom programming.

The CenTraVac chiller is uniquely suited for low-temperature applications like ice storage, because it provides multiple stages of compression. This allows the chiller to produce ice efficiently, while experiencing less stress than a single-stage compression chiller.

Hot-Water Control

This feature allows an external controller to enable/disable and modulate the hot-water control mode. Occasionally, CenTraVac chillers are used to provide heating as a primary operation. In this case the external controller or operator would select a hot-water temperature setpoint and the chiller capacity would be modulated to maintain the setpoint. Heating is the primary function and cooling is a waste product or a secondary function. This technique provides application flexibility, especially in multiple-chiller plants in conjunction with undersized heating plants.

The chiller needs only one condenser for hot-water control, whereas Heat Recovery uses a secondary condenser.

Refrigerant Monitor

The Extended Operation package allows for a refrigerant monitor to send a 4–20 mA signal to the Tracer AdaptiView control display. It can be calibrated to correspond to either 0–100 ppm or 0–1,000 ppm concentration levels. The concentration level is displayed at the Tracer AdaptiView control, but the chiller will not take any action based on the input from the refrigerant monitor.

Alternatively, a refrigerant monitor can be connected to Tracer Summit or Tracer SC, which has the ability to increase ventilation in the equipment room in response to high refrigerant concentrations.

Enhanced Flow Management Package

This option includes transducers for the differential evaporator-and-condenser-water pressures (psid). Flow switches or some other means to prove flow are still required and must be field connected. One type of sensor handles all pressure ranges up to 300 psig.

How It Works

The Tracer chiller controller uses a patented, variable, water-flow compensation algorithm to maintain stable, precise capacity control.

If the water-pressure transducer fails and the flow switch continues to prove flow, water-flow compensation will be disabled and the design delta-T will be used.

For applications designed to operate with variable-primary water flow, variable-flow compensation allows the chiller to respond quickly to changes in chilled-water flow rate. By automatically adjusting the control gain, large changes in the water-flow rate are accommodated.

Data shown on [Figure 27](#) demonstrates water-temperature control without flow compensation. In contrast, [Figure 28, p. 58](#) demonstrates water-temperature control with flow compensation enabled. The chilled-water temperature remains stable, even when the water flow rate drops 50 percent in 30 seconds.

Another benefit is disturbance rejection. [Figure 29, p. 58](#) shows the test results from step changes in water flow with increasing magnitudes. The leaving chilled-water temperature remains largely unaffected. Even the most severe change—dropping water flow 66 percent in 30 seconds—caused only a small, 1.5°F (-16.9°C) variation in chilled-water temperature. It is unlikely that a chiller application would make water flow changes of this magnitude. The results demonstrate that the chiller is more than capable of supporting variable water flow applications.

Figure 27. Capacity control without Enhanced Flow Management Package

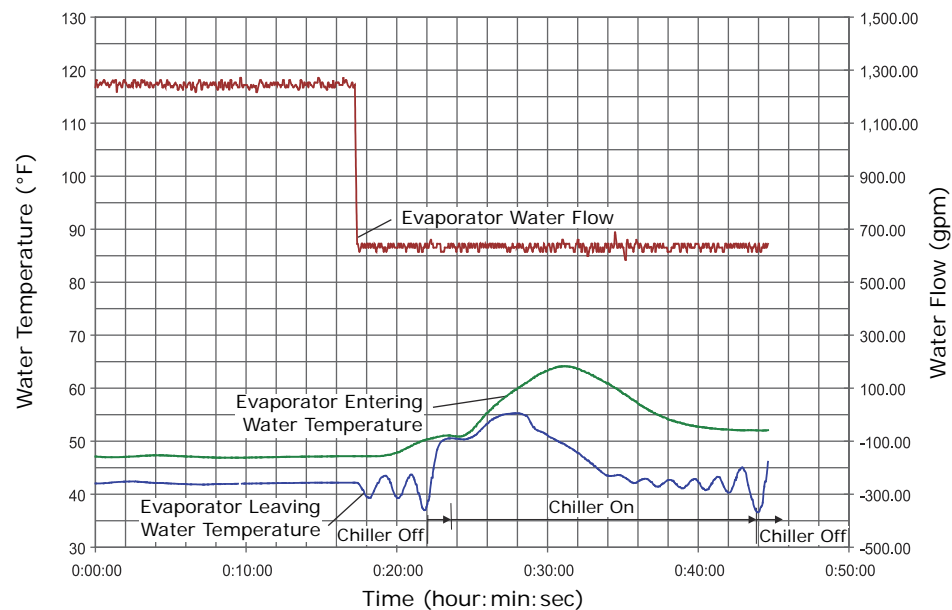

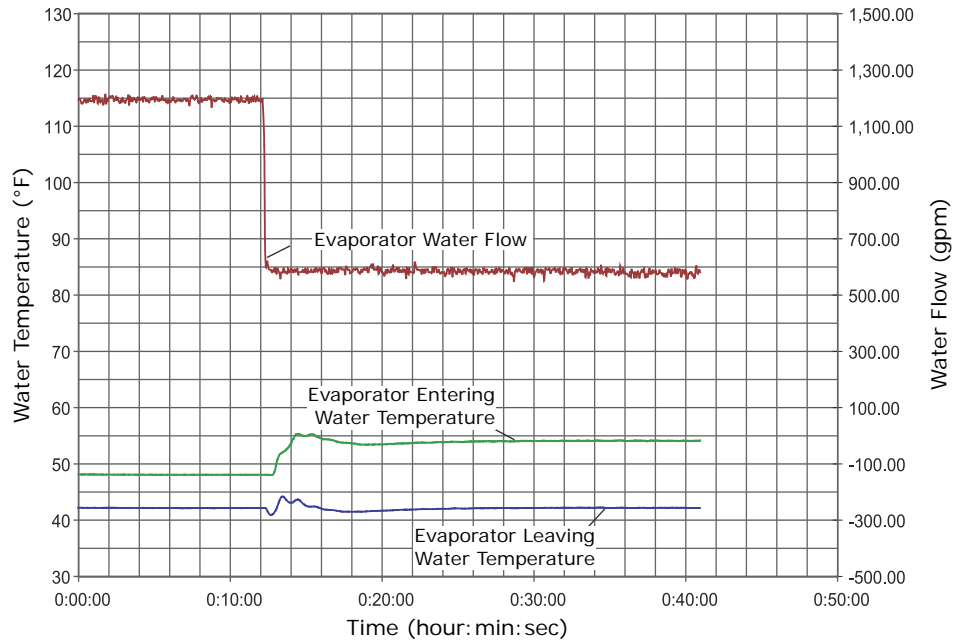
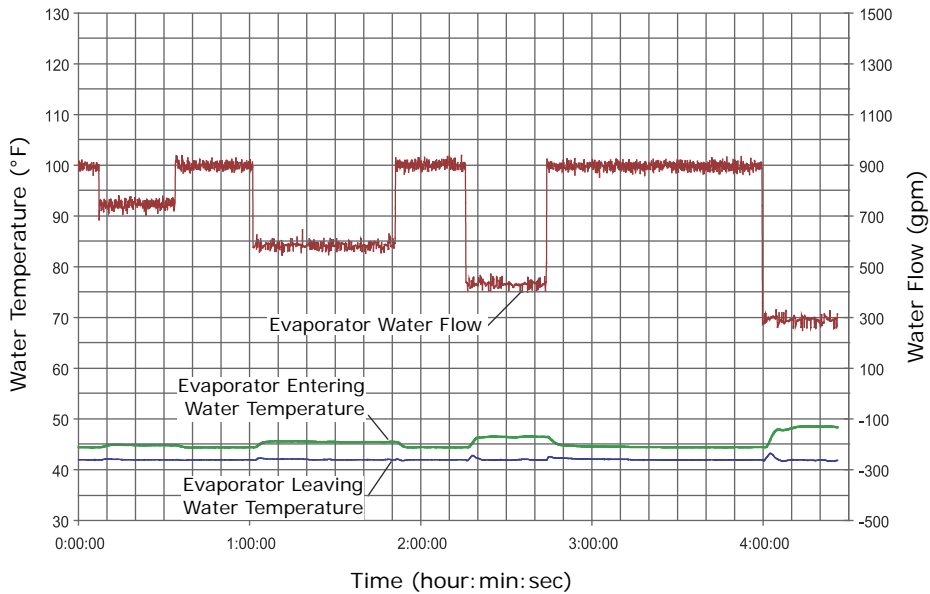
Variable-Flow Stability
Figure 28. Capacity control with Enhanced Flow Management Package

Figure 29. Capacity control with flow changes and Enhanced Flow Management Package

The following data will be shown at the Tracer AdaptiView control, Tracer TU displays and at Tracer Summit or Tracer SC:

- Evaporator tons
- Evaporator and condenser gpm
- Evaporator and condenser differential water pressures (psid)

It will automatically adjust capacity control to:

- Minimize variable-flow disturbance
- Maintain control stability at low flow

LonTalk Communications Interface (LCI-C)

The optional LonTalk® Communications Interface for Chillers (LCI-C) is available factory or field installed. It is an integrated communication board that enables the chiller controller to communicate over a LonTalk network. The LCI-C is capable of controlling and monitoring chiller setpoints, operating modes, alarms, and status. The Trane LCI-C provides additional points beyond the standard LONMARK® defined chiller profile to extend interoperability and support a broader range of system applications. These added points are referred to as open extensions. The LCI-C is certified to the LONMARK Chiller Controller Functional Profile 8040 version 1.0, and follows LonTalk FTT-10A free topology communications.

Native BACnet Communications

Tracer AdaptiView control can be configured for BACnet communications at the factory or in the field. This enables the chiller controller to communicate on a BACnet MS/TP network. Chiller setpoints, operating modes, alarms, and status can be monitored and controlled through BACnet.

Tracer AdaptiView controls conform to the BACnet B-ASC profile as defined by ASHRAE 135-2004.

Modbus Communications

Tracer AdaptiView control can be configured for Modbus communications at the factory or in the field. This enables the chiller controller to communicate as a slave device on a Modbus network. Chiller setpoints, operating modes, alarms, and status can be monitored and controlled by a Modbus master device.

Building Automation and Chiller Plant Control

Trane Tracer Summit and Tracer SC building automation systems include pre-engineered and flexible control for chiller plants. It can control the operation of the complete installation: chillers, pumps, cooling towers, isolating valves, air handlers, and terminal units. Trane can undertake full responsibility for optimized automation and energy management for the entire chiller plant. The main functions are:

- **Chiller sequencing:** equalizes the number of running hours of the chillers. Different control strategies are available depending on the configuration of the installation.
- **Control of the auxiliaries:** includes input/output modules to control the operation of the various auxiliary equipment (water pumps, valves, cooling towers, etc.)
- **Time-of-day scheduling:** allows the end user to define the occupancy period, for example: time of the day, holiday periods and exception schedules.
- **Optimization of the installation start/stop time:** based on the programmed schedule of occupancy and the historical temperature records. Tracer Summit and Tracer SC calculate the optimal start/stop time of the installation to get the best compromise between energy savings and comfort of the occupants.
- **Soft loading:** the soft loading function minimizes the number of chillers that are operated to satisfy a large chilled-water-loop pull down, thus preventing an overshoot of the actual capacity required. Unnecessary starts are avoided and the peak current demand is lowered.
- **Communication capabilities:** local, through a PC workstation keyboard. Tracer Summit and Tracer SC can be programmed to send messages to other local or remote workstations and or a pager in the following cases:
 - Analog parameter exceeding a programmed value
 - Maintenance warning
 - Component failure alarm
 - Critical alarm messages. In this latter case, the message is displayed until the operator acknowledges the receipt of the information. From the remote station it is also possible to access and modify the chiller plants control parameters.
- **Remote communication through a modem:** as an option, a modem can be connected to communicate the plant operation parameters through voice grade phone lines.

A remote terminal is a PC workstation equipped with a modem and software to display the remote plant parameters.

Chiller-Tower Optimization

Tracer Summit and Tracer SC chiller-tower optimization extends Adaptive Control to the rest of the chiller plant. Chiller-tower optimization is a unique control algorithm for managing the chiller and cooling-tower subsystem. It considers the chiller load and real-time ambient conditions, then optimizes the tower setpoint temperature to maximize the efficiency of the entire subsystem. This real-time optimization may vary tower temperatures between 50°F–90°F (10°C–32.2°C) depending upon current outdoor conditions, chiller loading, and ancillary efficiencies.

Integrated Comfort System (ICS)

The onboard Tracer chiller controller is designed to be able to communicate with a wide range of building automation systems. In order to take full advantage of chiller's capabilities, incorporate your chiller into a Tracer Summit or Tracer SC building automation system.

But the benefits do not stop at the chiller plant. At Trane, we realize that all the energy used in your cooling system is important. That is why we worked closely with other equipment manufacturers to predict the energy required by the entire system. We used this information to create patented control logic for optimizing HVAC system efficiency.

The building owners challenge is to tie components and applications expertise into a single reliable system that provides maximum comfort, control, and efficiency. Trane Integrated Comfort systems (ICS) are a concept that combines system components, controls, and engineering applications expertise into a single, logical, and efficient system. These advanced controls are fully commissioned and available on every piece of Trane® equipment, from the largest chiller to the smallest VAV box. As a manufacturer, only Trane offers this universe of equipment, controls, and factory installation and verification.



Standard Protections

The chiller controller uses proportional-integral-derivative (PID) control for all limits—there is no dead band. This removes oscillation above and below setpoints and extends the capabilities of the chiller.

Some of the standard protection features of the chiller controller are described in this section. There are additional protection features not listed here, contact your local Trane office for additional protection information.

High Condenser-Pressure Protection

The chiller will protect itself from a starter failure that prevents disconnecting the compressor motor from the incoming line power.

The chiller controller's condenser limit keeps the condenser pressure under a specified maximum pressure. The chiller will run up to 100 percent of this setpoint before the adaptive control mode reduces capacity.

Starter-Contactor Failure Protection

The chiller will protect itself from a starter failure that prevents the compressor motor from disconnecting from the line to the limits of its capabilities.

The controller starts and stops the chiller through the starter. If the starter malfunctions and does not disconnect the compressor motor from the line when requested, the controller will recognize the fault and attempt to protect the chiller by operating the evaporator and condenser water pumps, oil/refrigerant pumps and attempting to unload the compressor.

Loss of Water-Flow Protection

Tracer AdaptiView control has an input that will accept a contact closure from a proof-of-flow device such as a flow switch or pressure switch. Customer wiring diagrams also suggest that the flow switch be wired in series with the cooling-water and condenser-water pump starter auxiliary contacts. When this input does not prove flow within a fixed time during the transition from Stop to Auto modes of the chiller, or if the flow is lost while the chiller is in the Auto mode of operation, the chiller will be inhibited from running by a diagnostic.

Evaporator Limit Protection

Evaporator Limit is a control algorithm that prevents the chiller from tripping on its low refrigerant-temperature cutout. The machine may run down to the limit but not trip. Under these conditions the intended chilled-water setpoint may not be met, but the chiller will do as much as it can. The chiller will deliver as much cold water as possible even under adverse conditions.

Low Evaporator-Water Temperature

Low evaporator-water temperature protection, also known as Freeze Stat protection, avoids water freezing in the evaporator by immediately shutting down the chiller and attempting to operate the chilled-water pump. This protection is somewhat redundant with the Evaporator Limit protection, and prevents freezing in the event of extreme errors in the evaporator-refrigerant temperature sensor.

The cutout setting should be based on the percentage of antifreeze used in the customer's water loop. The chiller's operation and maintenance documentation provides the necessary information for percent antifreeze and suggests leaving-water temperature-cutout settings for a given chilled-water temperature setpoint.

High Vacuum-Lockout Protection

The controller inhibits a compressor start with a latching diagnostic whenever the evaporator pressure is less than or equal to 3.1 psia (21.4 kPa). This protects the motor by locking out chiller

operation while the unit is in a high vacuum—preventing startup without a refrigerant change during commissioning.

Oil-Temperature Protection

Low oil-temperature trips when the oil pump and/or compressor are running may be an indication of refrigerant diluting the oil. If the oil temperature is at or below the low oil-temperature setpoint, the compressor is shut down on a latching diagnostic and cannot be started. The diagnostic is reported at the user interface. The oil heater is energized in an attempt to raise the oil temperature above the low oil-temperature setpoint.

High oil-temperature protection is used to avoid overheating the oil and the bearings.

Low Differential Oil-Pressure Protection

Oil pressure is indicative of oil flow and active oil-pump operation. A significant drop in oil pressure indicates a failure of the oil pump, oil leakage, or a blockage in the oil circuit.

During compressor prelube the differential pressure should not fall below 12 psid. A shutdown diagnostic will occur within 2 seconds of the differential pressure falling below two-thirds of the low differential oil-pressure cutout.

When the compressor is running the shutdown diagnostic will occur when the differential pressure falls below the differential oil-pressure cutout for more than (cutout x 3) seconds. This allows for a relatively high cutout to be violated longer before triggering shutdown, as compared to a low cutout.

Excessive Purge Detection

Pump-out activity is indicative of the amount of air leaking into the chiller refrigerant system. The operator is informed when the air-leakage rate changes. Through this setpoint the operator can specify an expected leakage rate, and can be notified through a diagnostic if the rate is higher than expected.

Occasionally, when a service technician performs a mechanical repair on the chiller, an unusually high pump-out rate is expected for a certain period of time following the procedure. The service excessive pump-out override allows the technician to specify a time period for the purge system to rid the chiller of air in the system. This temporarily suspends excessive purge detection.

Phase-Unbalance Protection

Phase-unbalance protection is based on an average of the three-phase current inputs. The ultimate phase-unbalance trip point is 30 percent. In addition, the RLA of the motor is derated by resetting the active current limit setpoint based on the current unbalance. The RLA derate protection can be disabled in the field-startup menu.

The following derates apply when the phase-unbalance limit is enabled:

- 10% unbalance = 100% RLA available
- 15% unbalance = 90% RLA available
- 20% unbalance = 85% RLA available
- 25% unbalance = 80% RLA available
- 30% unbalance = Shutdown

Phase-Loss Protection

The controller will shut down the chiller if any of the three-phase currents feeding the motor drop below 10 percent RLA. The shutdown will result in a latching phase-loss diagnostic. The time to trip is 1 second at minimum, 3 seconds maximum.

Controls

Standard Protections

Phase Reversal/Rotation Protection

The controller detects reverse-phase rotation and provides a latching diagnostic when it is detected. The time to trip is 0.7 seconds.

Momentary Power Loss and Distribution Fault Protection

Three-phase momentary power loss (MPL) detection gives the chiller improved performance through many different power anomalies. MPLs of 2.5 cycles or longer will be detected and cause the unit to shut down. The unit will be disconnected from the line within 6 line cycles of detection. If enabled, MPL protection will be active any time the compressor is running. MPL is not active on reduced-voltage starters during startup to avoid nuisance trips. The MPL diagnostic is an automatic reset diagnostic.

An MPL has occurred when the motor no longer consumes power. An MPL may be caused by any drop or sag in the voltage that results in a change in the direction of power flow. Different operating conditions, motor loads, motor size, inlet guide vane position, etc., may result in different levels at which this may occur. It is difficult to define an exact voltage sag or voltage level at which a particular motor will no longer consume power, but we are able to make some general statements concerning MPL protection:

The chiller will remain running under the following conditions:

- Second-order or lower harmonic content on the line
- Control-voltage sags of any magnitude less than 3 line cycles
- Control-voltage sags of 40 percent or less for any amount of time
- Line-voltage sag of 1.5 line cycles or less for any voltage magnitude sag

The chiller may shut down under the following conditions:

- Line-voltage sags of 1.5 or more line cycles for voltage dips of 30 percent or more
- Third-order or higher harmonic content on the line
- Control-voltage sags of 3 or more line cycles for voltage dips of 40 percent or more

Current-Overload Protection

The control panel will monitor the current drawn by each line of the motor and shut the chiller off when the highest of the three line currents exceeds the trip curve. A manual reset diagnostic describing the failure will be displayed. The current overload protection does not prohibit the chiller from reaching its full-load amperage.

The chiller protects itself from damage due to current overload during starting and running modes, but is allowed to reach full-load amps.

High Motor-Winding Temperature Protection

This function monitors the motor temperature and terminates chiller operation when the temperature is excessive. The controller monitors each of the three winding-temperature sensors any time the controller is powered up, and displays each temperature at the service menu. The controller will generate a latching diagnostic if the winding temperature exceeds 265°F (129.4°C) for 0.5–2 seconds.

Surge Detection Protection

Surge detection is based on current fluctuations in one of three phases. The default detection criterion is two occurrences of root-mean square (RMS) current change of 30 percent within 0.8 seconds in 60 ±10 percent seconds. The detection criterion is adjustable with the Tracer chiller controller.

Overvoltage and Undervoltage Protection

While some components of the chiller are impervious to dramatically different voltages, the compressor-motor is not. The control panel monitors all three line-to-line voltages for the chiller,

and bases the over and undervoltage diagnostics on the average of the three voltages. The default protection resets the unit if the line voltage is below or above ± 10 percent of nominal for 60 seconds.

Power Factor and kW Measurement

Three-phase measurement of kW and unadjusted power factor yields higher accuracy during power imbalance conditions.

Short-Cycling Protection

This function mimics heat dissipation from a motor start using two setpoints: Restart Inhibit Free Starts and Restart Inhibit Start-to-Start Timer. This allows the CenTraVac to inhibit too many starts in a defined amount of time while still allowing for fast restarts. The default for CenTraVac is three Free Starts and a 20 minute Start-to-Start Timer. The control panel generates a warning when the chiller is inhibited from starting by this protection.

Restart Inhibit Free Starts: This setting will allow a maximum number of rapid restarts equal to its value. If the number of free starts is set to 1, this will allow only one start within the time period set by the Start-to-Start Time setting. The next start will be allowed only after the start-to-start timer has expired. If the number of free starts is programmed to 3, the control will allow three starts in rapid succession, but thereafter, it would hold off on a compressor start until the Start-to-Start timer expired.

Restart Inhibit Start-to-Start Time Setting: This setting defines the shortest chiller cycle period possible after the free starts have been used. If the number of free starts is programmed to 1, and the Start-to-Start Time setting is programmed to 10 minutes, the compressor will be allowed one start every 10 minutes. The start-to-start time is the time from when the motor was directed to energize to when the next prestart is issued.

Enhanced Protection Option

This optional package (included with the Enhanced Electrical Protection Package) includes sensors and transducers that enable the following protection features:

Enhanced Condenser-Limit Control

Includes factory-installed condenser-pressure transducer and all necessary interconnecting piping and wiring. Enhanced condenser-limit control provides high-pressure cutout avoidance by energizing a relay to initiate head relief.

Note: *This option is in addition to the standard high refrigerant-pressure safety contact.*

Compressor-Discharge Refrigerant-Temperature Protection (optional)

Includes a factory-installed sensor and safety cutout on high compressor-discharge temperature. Allows the chiller controller to monitor compressor-discharge temperature, which is displayed at Tracer AdaptiView control and operator interface, Tracer TU, Tracer Summit, and Tracer SC.

Note: *When the chiller is selected with HGBP, this sensor and its associated protection are included as standard.*

Sensing of Leaving Oil Set Temperature For Each Bearing

Optional factory-installed sensors allow high-temperature safety cutouts to monitor the leaving bearing-oil temperatures. The chiller controller, Tracer Summit, and Tracer SC display these temperatures. The high bearing-temperature cutout is fixed at 180°F (82.2°C). If either bearing temperature violates the cutout, a latching diagnostic will be generated.

Weights

Note: The weight information provided here should be used for general information purposes only. Trane does not recommend using this weight information for considerations relative to chiller rigging and placement. The large number of variances between chiller selections drives variances in chiller weights that are not recognized in this table. Use the weights from the selection program for better accuracy.

Table 4. Weights, 60 Hz compressors

Model	Comp Size		Evap Size	Cond Size	Without Starters				With Starters			
	NTON	CPKW	EVSZ	CDSZ	Operating Weights		Shipping Weights		Operating Weights		Shipping Weights	
					lb	kg	lb	kg	lb	kg	lb	kg
CVHE	230-320	287	032S	032S	14918	6767	13730	6228	17143	7776	15955	7237
	230-320	287	032S	032L	15484	7023	14195	6439	17709	8033	16420	7448
	230-320	287	032L	032L	16391	7435	14856	6739	18616	8444	17081	7748
	230-320	287	050S	050S	19275	8743	17163	7785	21500	9752	19388	8794
	230-320	287	050S	050L	20211	9168	17938	8137	22436	10177	20163	9146
	230-320	287	050L	050L	21738	9860	18910	8577	23963	10869	21135	9587
	360-500	453	050S	050S	20812	9440	18700	8482	23037	10449	20925	9491
	360-500	453	050S	050L	21748	9865	19475	8834	23973	10874	21700	9843
	360-500	453	050L	050L	23275	10557	20447	9275	25500	11567	22672	10284
	360-500	453	050S	080S	23540	10678	20910	9485	25765	11687	23135	10494
	360-500	453	050L	080L	26586	12059	23193	10520	28811	13068	25418	11529
	360-500	453	080S	080S	28529	12941	25002	11341	30754	13950	27227	12350
	360-500	453	080S	080L	30098	13652	26313	11935	32323	14661	28538	12945
	360-500	453	080L	080L	32186	14599	27893	12652	34411	15609	30118	13661
	350-570	588	050S	050S	19319	8763	17207	7805	22260	10097	20148	9139
	350-570	588	050S	050L	20255	9188	17982	8156	23196	10522	20923	9491
350-570	588	050L	050L	21682	9835	18954	8597	24623	11169	21895	9931	
350-570	588	050S	080S	21997	9978	19417	8807	24938	11312	22358	10141	
350-570	588	050L	080L	24993	11337	21700	9843	27934	12671	24641	11177	
350-570	588	080S	080S	27010	12252	23483	10652	29951	13586	26424	11986	
350-570	588	080S	080L	28579	12963	24794	11246	31520	14297	27735	12580	
350-570	588	080L	080L	30667	13910	26374	11963	33608	15244	29315	13297	
650-910	957	080S	080S	29385	13329	25858	11729	32275	14640	28748	13040	
650-910	957	080S	080L	30954	14040	27169	12324	33844	15351	30059	13635	
650-910	957	080L	080L	33042	14988	28749	13040	35932	16298	31639	14351	
650-910	957	080L	142L	38292	17369	32204	14607	41182	18680	35094	15918	
650-910	957	142M	142L	39210	17785	33278	15095	41525	18835	35437	16074	
650-910	957	142L	142L	40451	18348	34101	15468	42100	19096	36168	16406	
1070-1300	1228	080L	142L	40819	18515	34731	15754	43341	19659	36991	16779	
1070-1300	1228	142M	142L	41511	18829	35579	16138	43150	19573	37218	16882	
1070-1300	1228	142L	142L	42752	19392	36402	16512	44391	20135	38041	17255	
1070-1300	1228	142E	142L	43986	19952	37292	16915	45625	20695	38931	17659	
1070-1300	1228	210L	210L	51651	23428	43440	19704	53290	24172	45079	20447	
1070-1300	1228	250E	250L	60905	27626	50350	22838	62544	28369	51989	23582	
1470	1340	210L	210L	54232	24599	46021	20875	55871	25343	47660	21618	
1470-1720	1340	250E	250L	63486	28797	52931	24009	65125	29540	54570	24753	
1500-2000	745	210D	210D	76770	34822	66105	29985	82690	37508	72025	32670	
2170-2550	1062	250D	250D	87349	39621	73814	33481	90627	41108	77092	34968	
3000	1340	250M	250M	104574	47434	87557	39715	107852	48921	90835	41202	
3500	1340	250X	250X	112716	51127	93492	42407	115994	52614	96770	43894	

Note: These values represent chiller weights do not include the following:

1. TECU 0.028" tubes
2. 150 psig non-marine waterboxes
3. Enhanced Electrical Protection Package panel, add 50 lb (23 kg)
4. Control Panel Transformer option, add 130 lb (50 kg)
5. Supplemental Motor Protection option, add 500 lb (230 kg)
6. Operating weights include the heaviest possible refrigerant charge weight
7. Chillers with starter values include the weight of the heaviest possible starter
8. Heaviest possible bundle and heaviest possible motor voltage combination for the applicable family of chillers

Weights

Note: The weight information provided here should be used for general information purposes only. Trane does not recommend using this weight information for considerations relative to chiller rigging and placement. The large number of variances between chiller selections drives variances in chiller weights that are not recognized in this table. Use the weights from the selection program for better accuracy.

Table 5. Weights, 50Hz Compressors

Model	Comp Size		Evap Size	Cond Size	Without Starters				With Starters			
	NTON	CPKW			EVSZ	CDSZ	Operating Weights		Shipping Weights		Operating Weights	
			lb	kg			lb	kg	lb	kg	lb	kg
CVHE	190-270	242	032S	032S	14946	6779	13758	6241	16585	7523	15397	6984
	190-270	242	032S	032L	15512	7036	14223	6451	17151	7780	15862	7195
	190-270	242	032L	032L	16419	7448	14884	6751	18058	8191	16523	7495
	190-270	242	050S	050S	19303	8756	17191	7798	20942	9499	18830	8541
	190-270	242	050S	050L	20239	9180	17966	8149	21878	9924	19605	8893
	190-270	242	050L	050L	21766	9873	18938	8590	23405	10616	20577	9334
	300-420	379	050S	050S	20195	9160	18083	8202	21834	9904	19722	8946
	300-420	379	050S	050L	21131	9585	18858	8554	22770	10328	20497	9297
	300-420	379	050L	050L	22658	10277	19830	8995	24297	11021	21469	9738
	300-420	379	050S	080S	22923	10398	20293	9205	24562	11141	21932	9948
	300-420	379	050L	080L	25969	11779	22576	10240	27608	12523	24215	10984
	300-420	379	080S	080S	27912	12661	24385	11061	29551	13404	26024	11804
	300-420	379	080S	080L	29481	13372	25696	11656	31120	14116	27335	12399
	300-420	379	080L	080L	31569	14319	27276	12372	33208	15063	28915	13116
	CVHG	480-565	489	050S	050S	22009	9983	19897	9025	23648	10727	21536
480-565		489	050S	050L	22945	10408	20672	9377	24584	11151	22311	10120
480-565		489	050L	050L	24372	11055	21644	9818	26011	11798	23283	10561
480-565		489	050S	080S	24737	11221	22107	10028	26376	11964	23746	10771
480-565		489	050L	080L	27683	12557	24390	11063	29322	13300	26029	11807
480-565		489	080S	080S	29726	13483	26199	11884	31365	14227	27838	12627
480-565		489	080S	080L	31295	14195	27510	12478	32934	14939	29149	13222
480-565		489	080L	080L	33383	15142	29090	13195	35022	15886	30729	13938
670-780		621	080S	080S	31037	14078	27510	12478	32676	14822	29149	13222
670-780		621	080S	080L	32606	14790	28821	13073	34245	15533	30460	13816
670-780		621	080L	080L	34694	15737	30401	13790	36333	16480	32040	14533
670-780		621	080L	142L	40258	18261	34170	15499	41897	19004	41897	19004
920-1100		621	080L	142L	41324	18744	35236	15983	42963	19488	36875	16726
670-780		621	142M	142L	41176	18677	35244	15986	42815	19421	36883	16730
670-780		621	142L	142L	42417	19240	36067	16360	44056	19983	37706	17103
920-1100	892	142M	142L	42355	19212	36423	16521	43994	19955	38062	17265	
920-1100	892	142L	142L	43596	19775	37246	16895	45235	20518	38885	17638	
920-1100	892	210L	210L	52495	23811	44284	20087	54134	24555	45923	20830	
CDHG	1250	621	210D	210D	82845	37578	71980	32650	86123	39065	75258	34136
	1750	621	210D	210D	82845	37578	71980	32650	86123	39065	75258	34136
	2150	892	210D	210D	83957	38082	73092	33154	87235	39569	76370	34641
	2250	892	210D	210D	91423	41469	77888	35329	94701	42956	81166	36816

Note: These values represent chiller weights do not include the following:

1. TECU 0.028" tubes
2. 150 psig non-marine waterboxes
3. Enhanced Electrical Protection Package panel, add 50 lb (23 kg)
4. Control Panel Transformer option, add 130 lb (50 kg)
5. Supplemental Motor Protection option, add 500 lb (230 kg)
6. Operating weights include the heaviest possible refrigerant charge weight
7. Chillers with starter values include the weight of the heaviest possible starter
8. Heaviest possible bundle and heaviest possible motor voltage combination for the applicable family of chillers

Physical Dimensions

Single Compressor CenTraVac Chillers

Table 6. CenTraVac water connection pipe size

Water Passes	Shell Size					
	032	050	080	142	210	250
Evaporator			Nominal Pipe Size (in.)			
1 Pass	8	10	12	16	16	16
2 Pass	6	8	10	12	14	14
3 Pass	5	6	8	10	12	12
Condenser						
1 Pass	8	10	12	16	16	16
2 Pass	6	8	10	12	14	14
Evaporator			Metric Pipe Size (mm)			
1 Pass	DN200	DN250	DN350	DN400	DN400	DN400
2 Pass	DN150	DN200	DN250	DN300	DN350	DN350
3 Pass	DN125	DN150	DN200	DN250	DN300	DN300
Condenser						
1 Pass	DN200	DN250	DN350	DN400	DN400	DN400
2 Pass	DN150	DN200	DN250	DN300	DN350	DN350

Figure 30. For Table 8, p. 71 and Table 7, p. 70: Space envelope for 50 and 60 Hz compressor chillers^(a)

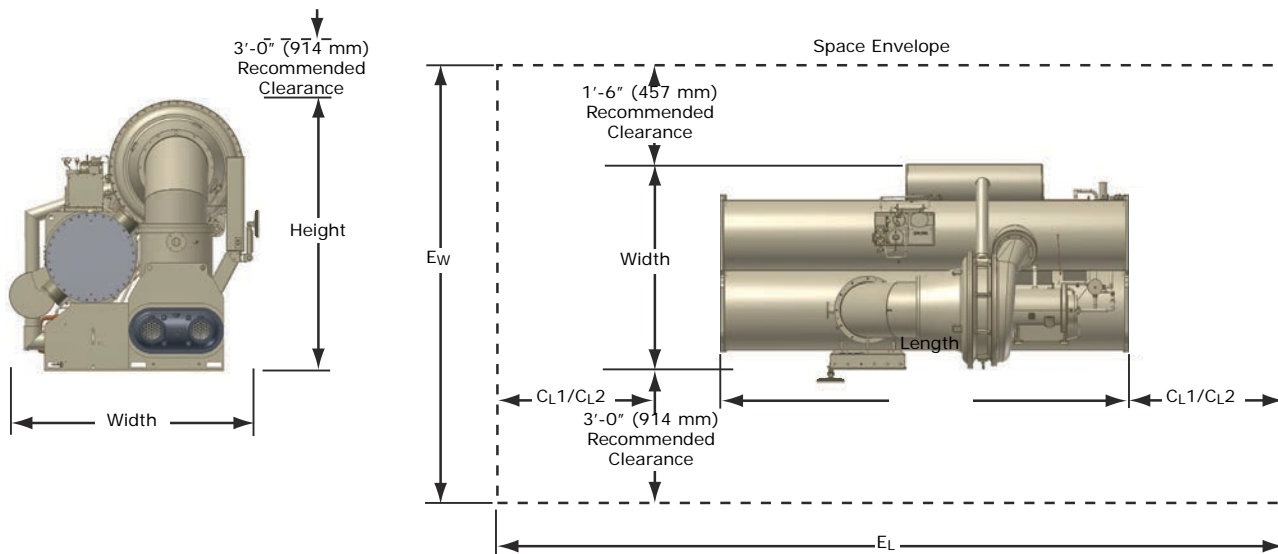

(a) Without unit-mounted starters.



Physical Dimensions

Single Compressor CenTraVac Chillers

Table 7. For Figure 30, p. 69: Physical dimensions 60 Hz compressor chillers (in. and mm)

Model	Comp Size	Shell Size	Shell Arrange	Envelope				Clearance		Base Unit Dimensions			
				Length	Width			Tube Pull		Length	Height	Width	
					Terminal Box Only	LV Unit Mounted Starters ^(a)	LV Unit Mounted AFD	C _{L1}	C _{L2}				
				E _L	E _w	E _w	E _w	IP Units (in.)					
CVHE	230–320	032	SS	317	124	134	149	141	41	135.0	93.9	70.4	
			SL / LL	408	124	134	149	186	41	180.3	93.9	70.4	
		050	SS	318	136	148	155	141	42	135.0	98.4	82.1	
			SL / LL	409	136	148	155	186	42	180.3	98.4	82.1	
	360–500	050	SS	318	136	147	155	141	42	135.0	98.7	82.1	
			SL / LL	409	136	147	155	186	42	180.3	98.7	82.1	
		050/080	SS	328	143	149	165	141	52	135.0	103.8	89.2	
			LL	419	143	149	165	186	52	180.3	103.8	89.2	
	CVHF	350–570	080	SS	328	150	148	165	141	52	135.0	114.9	95.5
				SL / LL	419	150	148	165	186	52	180.3	114.9	95.5
			050	SS	318	136	147	155	141	42	135.0	100.0	82.1
				SL / LL	409	136	147	155	186	42	180.3	100.0	82.1
650–910		050/080	SS	328	144	149	166	141	52	135.0	103.7	90.0	
			LL	419	144	149	166	186	52	180.3	103.7	90.0	
		080	SS	328	150	148	165	141	52	135.0	114.9	95.5	
			SL / LL	419	150	148	165	186	52	180.3	114.9	95.5	
1070–1300		142	SS	328	150	157	181	141	52	135.0	114.9	95.5	
			SL / LL	419	150	157	181	186	52	180.3	114.9	95.5	
		080/142	LL	426	175	170	200	186	59	180.3	117.8	120.6	
			ML / LL	426	171	168	198	186	59	180.3	121.3	117.1	
1470–1720	210	SS	426	176	173	208	186	59	180.3	121.6	121.8		
		ML / LL	426	173	173	200	186	59	180.3	121.5	119.1		
	250	EL	471	173	173	200	209	59	202.8	121.5	119.1		
		LL	426	181	177	206	186	59	180.3	135.2	126.5		
CVHE	230–320	032	SS	8052	3160	3391	3782	3581	1041	3429	2385	1788	
			SL / LL	10351	3160	3391	3782	4731	1041	4578	2385	1788	
		050	SS	8077	3457	3762	3942	3581	1067	3429	2499	2085	
			SL / LL	10376	3457	3762	3942	4731	1067	4578	2499	2085	
	360–500	050	SS	8077	3457	3721	3942	3581	1067	3429	2507	2085	
			SL / LL	10376	3457	3721	3942	4731	1067	4578	2507	2085	
		050/080	SS	8331	3637	3780	4199	3581	1321	3429	2637	2266	
			LL	10630	3637	3780	4199	4731	1321	4578	2637	2266	
	CVHF	350–570	080	SS	8331	3797	3754	4181	3581	1321	3429	2918	2426
				SL / LL	10630	3797	3754	4181	4731	1321	4578	2918	2426
			050	SS	8077	3457	3726	3942	3581	1067	3429	2540	2085
				SL / LL	10376	3457	3726	3942	4731	1067	4578	2540	2085
650–910		050/080	SS	8331	3658	3785	4206	3581	1321	3429	2634	2286	
			LL	10630	3658	3785	4206	4731	1321	4578	2634	2286	
		080	SS	8331	3797	3754	4181	3581	1321	3429	2918	2426	
			SL / LL	10630	3797	3754	4181	4731	1321	4578	2918	2426	
1070–1300		080	SS	8331	3797	3978	4592	3581	1321	3429	2918	2426	
			SL / LL	10630	3797	3978	4592	4731	1321	4578	2918	2426	
		080/142	LL	10808	4435	4321	5075	4731	1499	4578	2992	3063	
			ML / LL	10808	4346	4262	5029	4731	1499	4578	3081	2974	
1470–1720	210	SS	10808	4465	4387	5273	4731	1499	4578	3089	3094		
		ML / LL	10808	4397	4387	5080	4731	1499	4578	3086	3025		
	250	EL	11951	4397	4387	5080	5302	1499	5150	3086	3025		
		LL	10809	4585	4496	5243	4732	1499	4579	3434	3213		
250	EL	12027	4900	4945	5436	5302	1575	5150	3541	3528			
	LL	10808	4585	4496	5243	4731	1499	4578	3485	3213			
250	EL	12027	4900	4945	5436	5302	1575	5150	3592	3528			

Notes:

1. C_{L1} can be at either end of the machine and is required for tube pull clearance.
2. C_{L2} is always at the opposite end of the machine from C_{L1} and is required for service clearance.
3. DMP = Differential Motor Protection
4. SMP = Supplemental Motor Protection, no unit-mounted starter
5. CPTR = Control Power Transformer option, no unit-mounted starter

(a) Dimensions for low-voltage unit-mounted starters. Medium-voltage starters are also available for unit mounting.

Physical Dimensions

Single Compressor CenTraVac Chillers

Table 8. For Figure 30, p. 69: Physical dimensions 50 Hz compressor chillers (in. and mm)

Model	Comp Size	Shell Size	Shell Arrange	Envelope			Clearance		Base Unit Dimensions			
				Length	Width		Tube Pull		Length	Height	Width	
					Terminal Box Only	LV Unit Mounted Starters ^(a)	CL1	CL2				
				EL	EW	EW	IP Units (in.)					
CVHE	190-270	032	SS	317	124	134	141	41	135.0	93.9	70.4	
			SL / LL	408	124	134	186	41	180.3	93.9	70.4	
		050	SS	318	136	148	141	42	135.0	98.4	82.1	
			SL / LL	409	136	148	186	42	180.3	98.4	82.1	
	300-420	050	SS	318	136	147	141	42	135.0	98.7	82.1	
			SL / LL	409	136	147	186	42	180.3	98.7	82.1	
		050/080	SS	328	143	149	141	52	135.0	103.8	89.2	
			LL	419	143	149	186	52	180.3	103.8	89.2	
	CVHG	480-565	080	SS	328	150	148	141	52	135.0	114.9	95.5
				SL / LL	419	150	148	186	52	180.3	114.9	95.5
			050	SS	318	136	147	141	42	135.0	103.0	82.4
				SL / LL	409	136	147	186	42	180.3	103.0	82.4
670-780		050/080	SS	328	145	150	141	52	135.0	104.7	91.4	
			LL	419	145	150	186	52	180.3	104.7	91.4	
		080	SS	328	150	149	141	52	135.0	115.8	95.5	
			SL / LL	419	150	149	186	52	180.3	115.8	95.5	
920-1067		080	SS	328	150	157	141	52	135.0	114.7	95.5	
			SL / LL	419	150	157	186	52	180.3	114.7	95.5	
		080/142	LL	426	175	170	186	59	180.3	117.8	120.9	
			ML / LL	426	171	168	186	59	180.3	121.2	117.1	
	142	LL	426	176	173	186	59	180.3	119.4	121.8		
		ML / LL	426	171	173	186	59	180.3	121.2	117.1		
	210	LL	426	181	177	186	59	180.3	132.8	126.5		
		LL	426	176	173	186	59	180.3	121.6	121.8		
1100	142	ML / LL	426	171	173	186	59	180.3	121.5	117.1		
	210	LL	426	181	177	186	59	180.3	135.2	126.5		
SI Units (mm)												
CVHE	190-270	032	SS	8052	3160	3391	3581	1041	3429	2385	1788	
			SL / LL	10351	3160	3391	4731	1041	4578	2385	1788	
		050	SS	8077	3457	3762	3581	1067	3429	2499	2085	
			SL / LL	10376	3457	3762	4731	1067	4578	2499	2085	
	300-420	050	SS	8077	3457	3721	3581	1067	3429	2507	2085	
			SL / LL	10376	3457	3721	4731	1067	4578	2507	2085	
		050/080	SS	8331	3637	3780	3581	1321	3429	2637	2266	
			LL	10630	3637	3780	4731	1321	4578	2637	2266	
	CVHG	480-565	080	SS	8331	3797	3754	3581	1321	3429	2918	2426
				SL / LL	10630	3797	3754	4731	1321	4578	2918	2426
			050	SS	8077	3465	3741	3581	1067	3429	2616	2093
				SL / LL	10376	3465	3741	4731	1067	4578	2616	2093
670-780		050/080	SS	8331	3693	3815	3581	1321	3429	2659	2322	
			LL	10630	3693	3815	4731	1321	4578	2659	2322	
		080	SS	8331	3797	3787	3581	1321	3429	2941	2426	
			SL / LL	10630	3797	3787	4731	1321	4578	2941	2426	
920-1067		080	SS	8331	3797	3978	3581	1321	3429	2913	2426	
			SL / LL	10630	3797	3978	4731	1321	4578	2913	2426	
		080/142	LL	10808	4442	4321	4731	1499	4578	2992	3071	
			ML / LL	10808	4346	4262	4731	1499	4578	3078	2974	
	142	LL	10808	4465	4387	4731	1499	4578	3033	3094		
		ML / LL	10808	4346	4387	4731	1499	4578	3078	2974		
	210	LL	10809	4585	4496	4732	1499	4579	3373	3213		
		LL	10810	4465	4387	4732	1499	4580	3089	3094		
1100	142	ML / LL	10808	4346	4387	4731	1499	4578	3086	2974		
	210	LL	10810	4585	4496	4732	1499	4580	3434	3213		

Notes:

1. CL1 can be at either end of the machine and is required for tube pull clearance.
2. CL2 is always at the opposite end of the machine from CL1 and is required for service clearance.
3. DMP = Differential Motor Protection
4. SMP = Supplemental Motor Protection, no unit-mounted starter
5. CPTR = Control Power Transformer option, no unit-mounted starter

(a) Dimensions for low-voltage unit-mounted starters. Medium-voltage starters are also available for unit mounting.

Dual Compressor CenTraVac Chillers

Table 9. CenTraVac water connection pipe sizes

Water Passes	Shell Size			
	210D	250D	250M	250X
Evaporator	Nominal Pipe Size (in.)			
1 Pass	16	16	18	18
Condenser	Nominal Pipe Size (mm)			
1 Pass	16	16	20	20
Evaporator	Nominal Pipe Size (mm)			
1 Pass	DN400	DN400	458	458
Condenser	Nominal Pipe Size (mm)			
1 Pass	DN400	DN400	508	508

Figure 31. For Table 10: Space envelope for dual 50 and 60 Hz compressor chillers^(a)

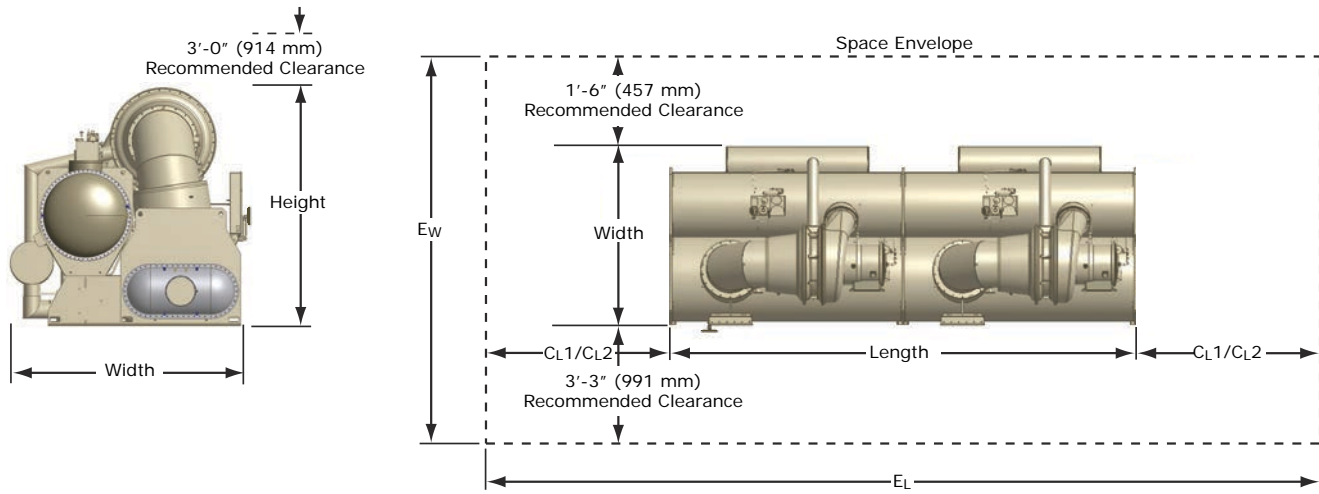

(a) Without unit-mounted starters.

Physical Dimensions

Dual Compressor CenTraVac Chillers

Table 10. For Figure 31: Physical dimensions dual 60 and 50 Hz compressor units (in. and mm)

Model	Comp Size	Shell Size	Shell Arrange	Envelope			Clearance		Base Unit Dimensions			
				Length	Width		Tube Pull	C _{L1}	C _{L2}	Length	Height	Width
					Terminal Box Only	MV Unit Mounted Starters						
				E _L	E _w	E _w	E _w	C _{L1}	C _{L2}			
IP Units (in.)												
CDHF	1500	210	DD	606	186	188	206	264	84	258	132.8	131.5
	2000											
	2170	250	DD	606	197	203	214	264	84	258	139.3	142.5
	2550											
3000	250	MM	714	191	195	214	318	84	312	141.3	137.3	
3500	250	XX	810	191	195	214	366	84	360	141.3	137.3	
CDHG	1250	210	DD	606	197	188	N/A	264	84	258	132.8	142.5
	1750											
	2150	210	DD	606	197	189	N/A	264	84	258	133.1	142.5
	2250	210	DD	606	197	191	N/A	264	84	258	135.4	142.5
SI Units (mm)												
CDHF	1500	210	DD	15392	4724	4775	5232	6706	2134	6553	3373	3340
	2000											
	2170	250	DD	15392	5004	5156	5436	6706	2134	6553	3538	3620
	2550											
3000	250	MM	18136	4851	4953	5436	8077	2134	7925	3589	3487	
3500	250	XX	20574	4851	4953	5436	9296	2134	9144	3589	3487	
CDHG	1250	210	DD	15392	5004	4775	N/A	6706	2134	6553	3373	3620
	1750											
	2150	210	DD	15392	5004	4801	N/A	6706	2135	6553	3381	3620
	2250	210	DD	15392	5004	4851	N/A	6706	2134	6553	3439	3620

Notes:

1. C_{L1} can be at either end of the machine and is required for tube pull clearance.
2. C_{L2} is always at the opposite end of the machine from C_{L1} and is required for service clearance.

Chiller Views

Note: *Figure 32 shows five different views of the CenTraVac chiller: front, left, right, top, and rear view. These views and various combinations are used in Figure 33, p. 75 through Figure 42, p. 79, and are intended to help you visualize the possible connections and combinations that may be available for your unit. You must contact your local Trane office to configure your selection for an as-built drawing to confirm it is available and to provide appropriate dimensions.*

Figure 32. Front, left, right, top, and rear views of the CenTraVac chiller

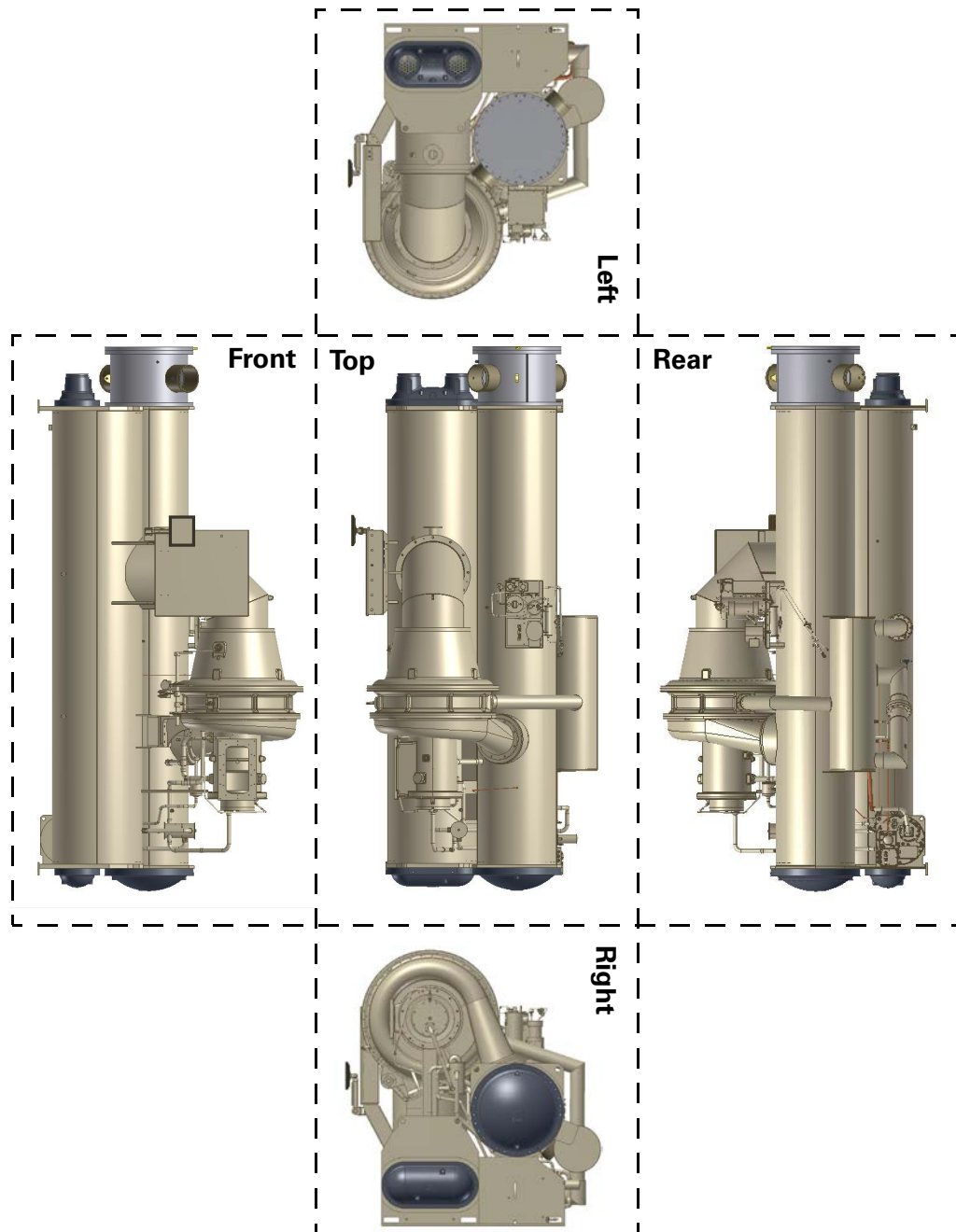

Evaporator Waterbox Configuration

Note: *Figure 33 through Figure 38, p. 76 are intended to help you visualize the possible connections and combinations that may be available for your unit. You must contact your local Trane office to configure your selection for an as-built drawing to confirm it is available and to provide appropriate dimensions.*

Figure 33. Two-pass non-marine

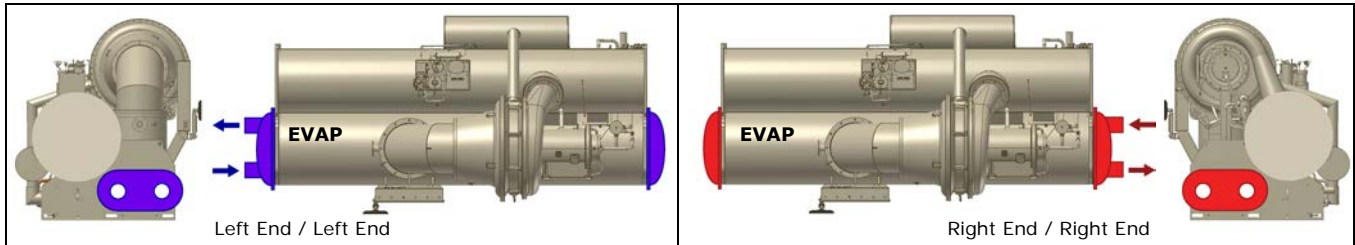

Figure 34. Two-pass non-marine (250E only)

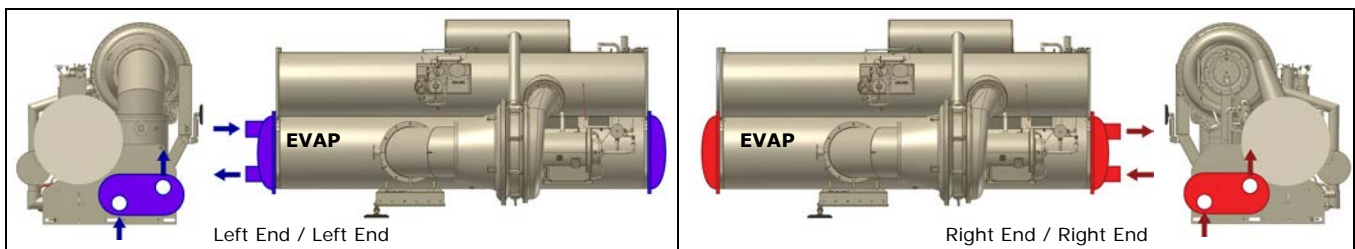

Figure 35. One-pass or three-pass non-marine

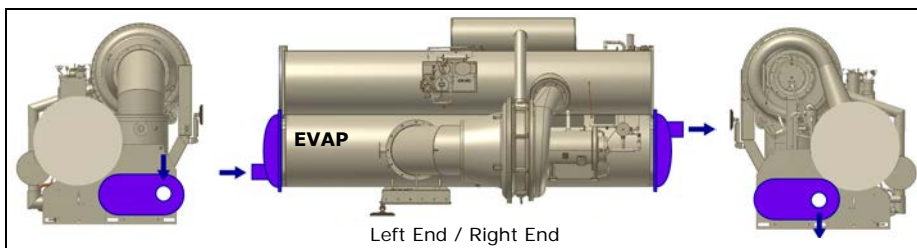
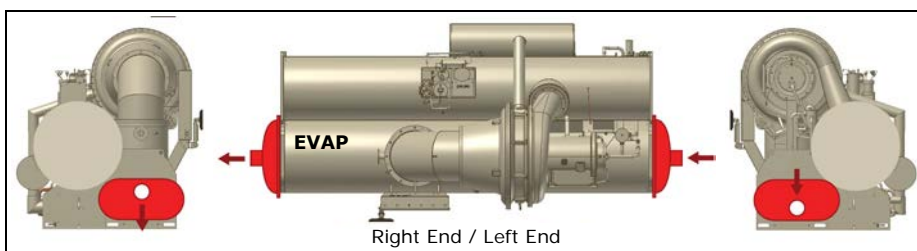

Figure 36. One-pass or three-pass non-marine (250E only)



Physical Dimensions

Evaporator Waterbox Configuration

Figure 37. Two-pass marine

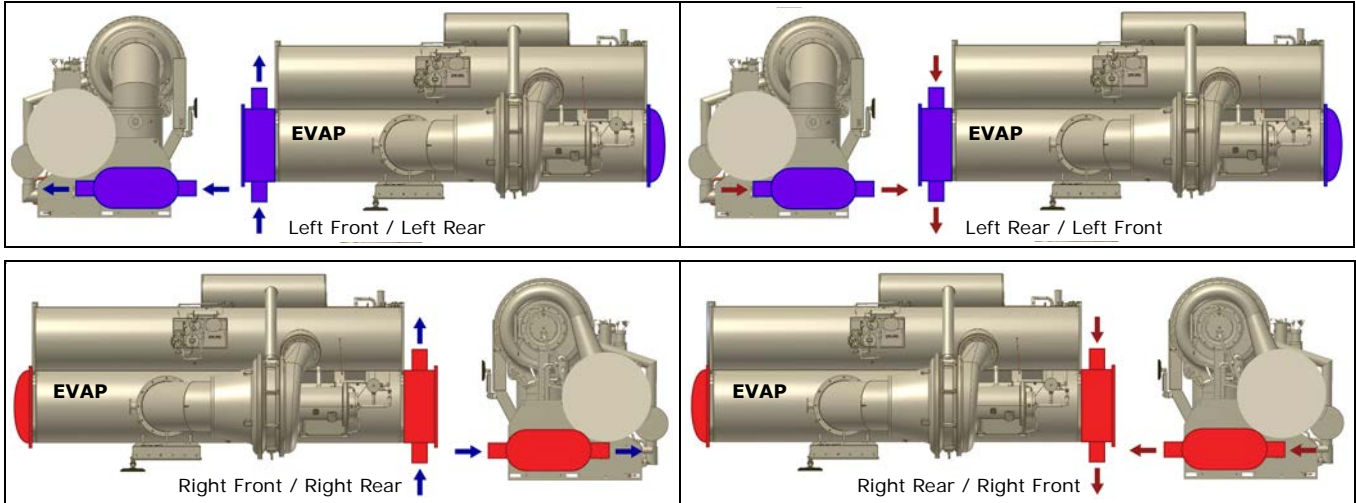

Figure 38. One-pass or three-pass marine

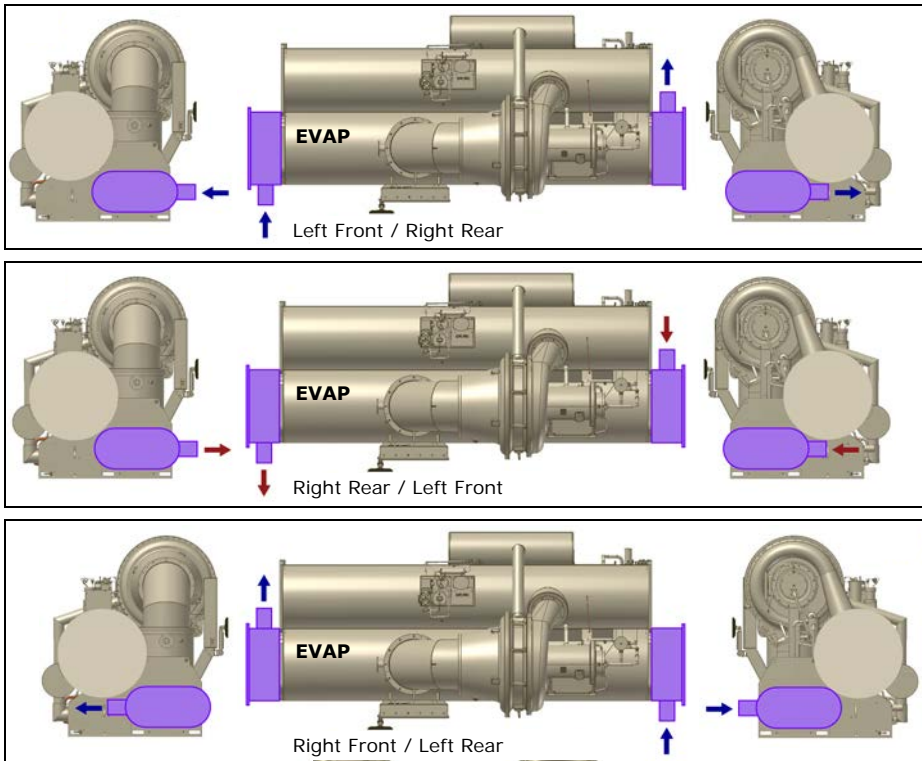
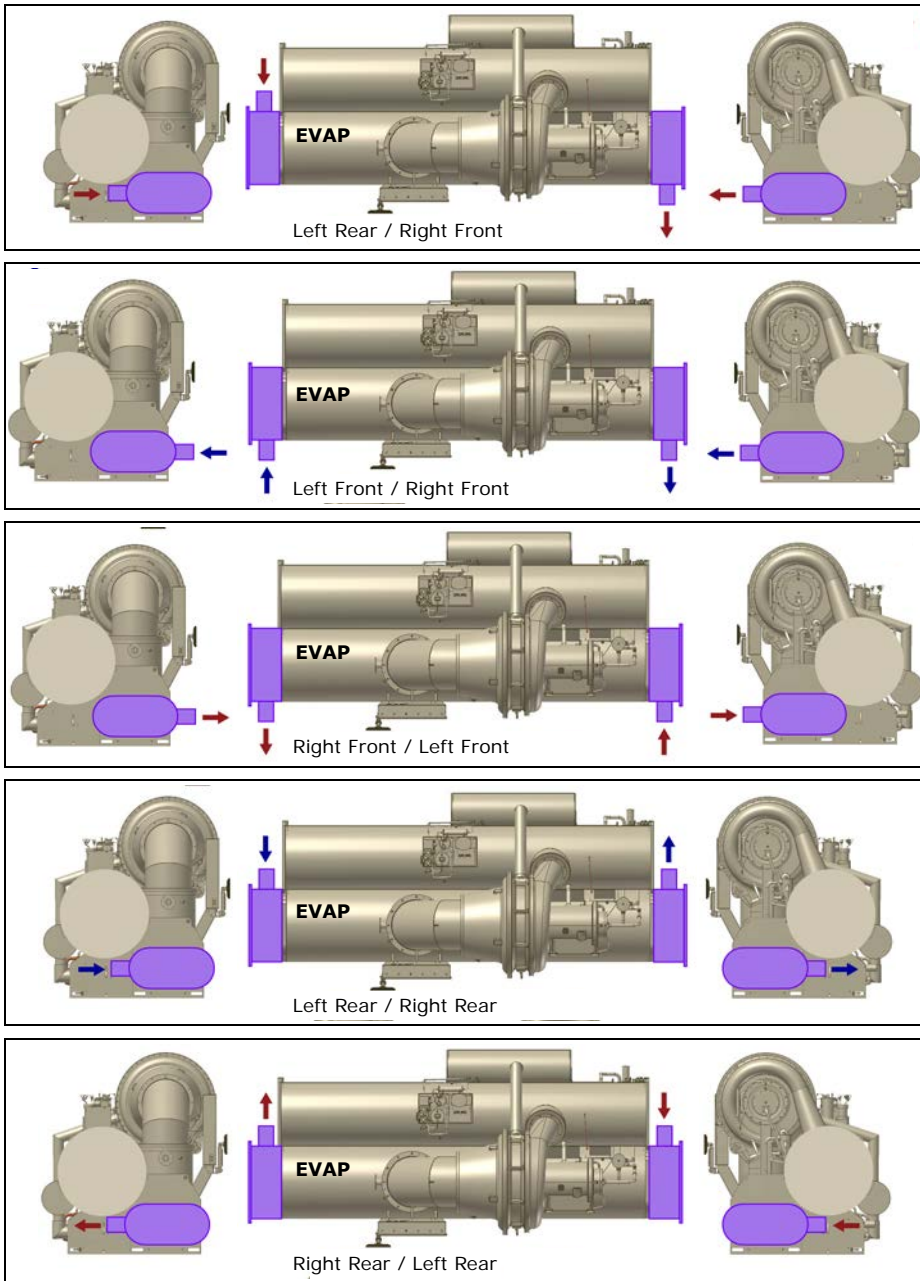

Figure 38. One-pass or three-pass marine (continued)



Condenser Waterbox Configuration

Note: *Figure 39 through Figure 42, p. 79 are intended to help you visualize the possible connections and combinations that may be available for your unit. You must contact your local Trane office to configure your selection for an as-built drawing to confirm it is available and to provide appropriate dimensions.*

Figure 39. Two-pass non-marine

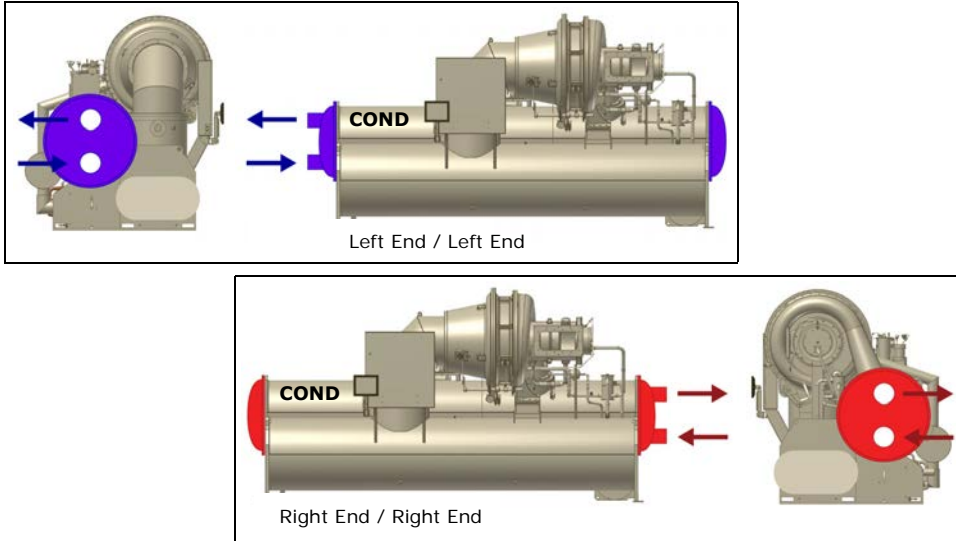
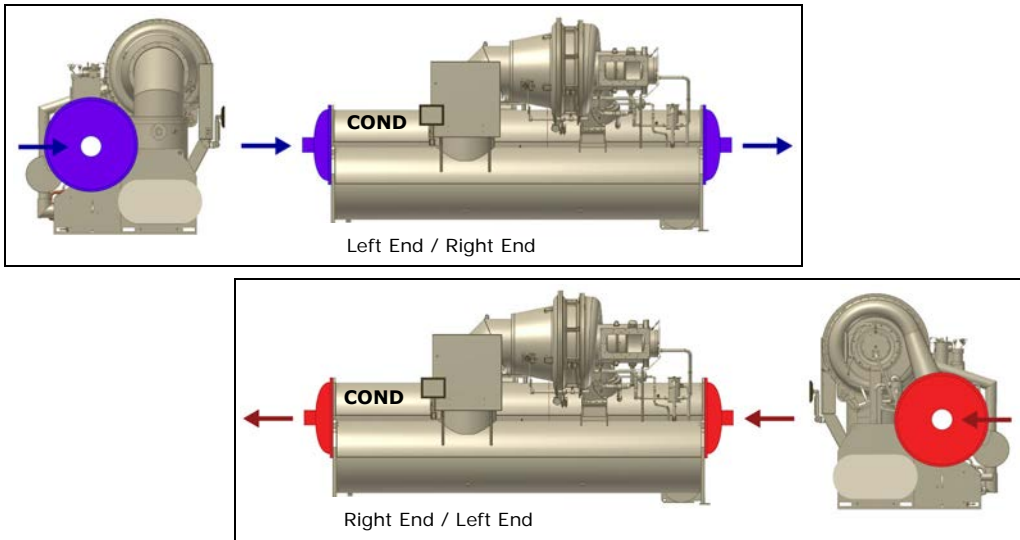

Figure 40. One-pass non-marine



Physical Dimensions

Condenser Waterbox Configuration

Figure 41. Two-pass marine

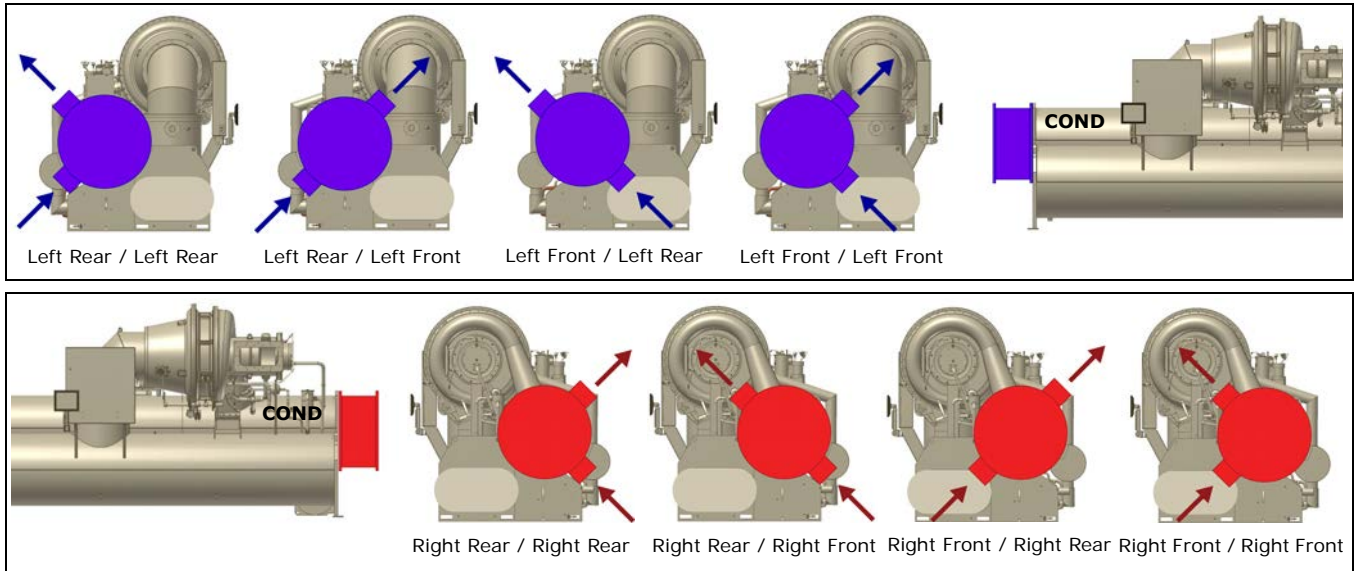
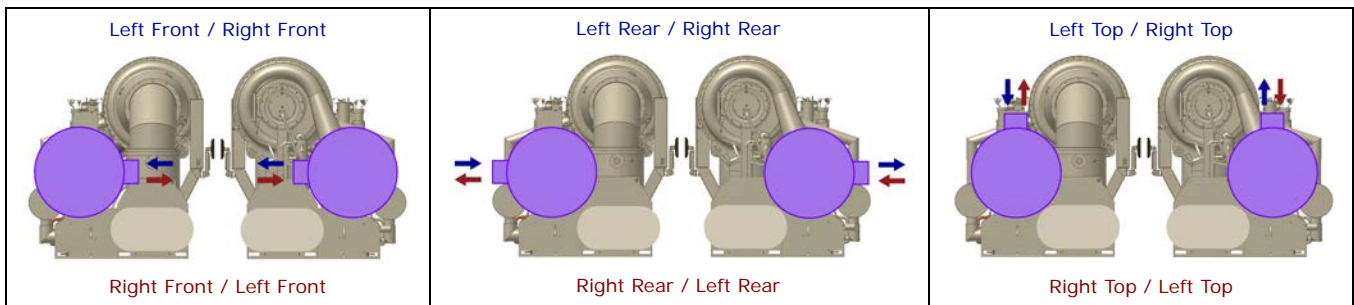

Figure 42. One-pass marine





Physical Dimensions

Waterbox Lengths

Table 11. Waterbox lengths, 150 psig (in. and mm)

	Evaporator						Condenser								
	Shell	Passes	Supply Length		Return Length		Supply Length		Return Length		Passes	Shell			
			in.	mm	in.	mm	in.	mm	in.	mm					
150 psig	Non-Marine	320	1	12.8	325	—	—	13.0	330	—	—	1	Non-Marine		
			2	12.8	325	6.8	173	9.3	235	6.1	154	2		320	
			3	12.8	325	—	—	—	—	—	—	3			
		500	1	12.7	324	—	—	13.9	353	—	—	1		500	
			2	12.7	323	7.4	188	10.5	267	8.0	202	2			
			3	12.7	323	—	—	—	—	—	—	3			
		800	1	13.2	335	—	—	15.9	404	—	—	1			800
			2	13.2	335	7.3	185	14.1	357	8.8	224	2			
			3	13.2	335	—	—	—	—	—	—	3			
	1420	1	14.6	370	—	—	19.0	482	—	—	1	1420			
		2	14.6	370	8.4	214	17.5	443	13.6	345	2				
		3	14.6	370	—	—	—	—	—	—	3				
	2100	1	16.0	406	—	—	19.5	496	—	—	1		2100		
		2	16.0	406	9.6	243	17.9	455	14.1	359	2				
		3	16.0	406	—	—	—	—	—	—	3				
	2500	1	18.9	480	—	—	20.5	521	—	—	1			2500	
		2	18.9	479	10.4	264	19.3	489	15.1	384	2				
		3	18.9	479	—	—	—	—	—	—	3				
2100 (Duplex)	1	16.0	406	—	—	19.5	495	—	—	1	2100 (Duplex)				
2500 (Duplex)	1	18.9	480	—	—	20.5	521	—	—	1	2500 (Duplex)				
150 psig	Marine	320	1	15.9	403	—	—	17.1	435	—	—	1			Marine
			2	15.9	403	6.8	173	16.8	426	6.1	154	2	320		
			3	15.9	403	—	—	—	—	—	—	3			
		500	1	18.3	464	—	—	21.3	542	—	—	1	500		
			2	18.3	464	7.4	188	15.9	405	8.0	202	2			
			3	18.3	464	—	—	—	—	—	—	3			
		800	1	23.2	590	—	—	22.9	583	—	—	1		800	
			2	21.2	540	7.3	185	23.3	591	8.8	224	2			
			3	19.2	489	—	—	—	—	—	—	3			
	1420	1	27.9	709	—	—	39.5	1004	—	—	1	1420			
		2	24.7	626	8.4	214	37.5	953	13.6	345	2				
		3	22.7	575	—	—	—	—	—	—	3				
	2100	1	28.4	721	—	—	40.5	1030	—	—	1		2100		
		2	27.4	696	9.6	243	38.3	973	14.1	359	2				
		3	25.4	645	—	—	—	—	—	—	3				
	2500	1	30.2	766	—	—	45.0	1144	—	—	1			2500	
		2	30.2	766	10.4	264	41.0	1042	15.1	384	2				
		3	—	—	—	—	—	—	—	—	3				
2100 (Duplex)	1	28.4	721	—	—	40.5	1029	—	—	1	2100 (Duplex)				
2500 (Duplex)	1	30.2	767	—	—	45.0	1143	—	—	1	2500 (Duplex)				

Physical Dimensions

Waterbox Lengths

Table 12. Waterbox lengths, 300 psig (in. and mm)

	Evaporator						Condenser								
	Shell	Passes	Supply Length		Return Length		Supply Length		Return Length		Passes	Shell			
			in.	mm	in.	mm	in.	mm	in.	mm					
300 psig	Non-Marine	320	1	12.8	325	—	—	13.3	339	—	—	1	Non-Marine		
			2	12.8	325	6.8	173	20.1	510	7.6	193	2		320	
			3	12.8	325	—	—	—	—	—	—	3			
		500	1	12.7	324	—	—	16.4	416	—	—	1			500
			2	12.7	322	6.7	171	20.3	516	8.2	209	2			
			3	12.7	323	—	—	—	—	—	—	3			
		800	1	13.8	351	—	—	16.5	420	—	—	1		800	
			2	13.8	351	7.1	179	23.1	588	8.6	217	2			
			3	13.8	351	—	—	—	—	—	—	3			
	1420	1	15.6	396	—	—	15.7	398	—	—	1	1420			
		2	15.6	396	8.8	224	15.7	398	9.7	246	2				
		3	15.6	396	—	—	—	—	—	—	3				
	2100	1	16.8	428	—	—	20.7	526	—	—	1		2100		
		2	16.8	428	9.8	250	20.4	518	13.7	348	2				
		3	16.8	428	—	—	—	—	—	—	3				
	2500	1	20.3	514	—	—	21.8	553	—	—	1			2500	
		2	20.3	514	13.3	337	21.7	552	14.7	375	2				
		3	20.3	514	—	—	—	—	—	—	3				
2100 (Duplex)	1	16.8	428	—	—	20.7	526	—	—	1	2100 (Duplex)				
2500 (Duplex)	1	20.3	514	—	—	21.8	553	—	—	1	2500 (Duplex)				
300 psig	Marine	320	1	15.9	403	—	—	17.2	437	—	—	1			Marine
			2	15.9	403	6.8	173	17.0	431	7.6	193	2	320		
			3	15.9	403	—	—	—	—	—	—	3			
		500	1	18.9	480	—	—	23.6	600	—	—	1			
			2	18.9	480	6.7	171	18.2	463	8.2	209	2			
			3	18.9	480	—	—	—	—	—	—	3			
		800	1	25.3	642	—	—	28.5	725	—	—	1	800		
			2	23.3	591	7.1	179	28.0	712	8.6	217	2			
			3	21.3	541	—	—	—	—	—	—	3			
	1420	1	29.9	760	—	—	35.0	890	—	—	1	1420			
		2	26.7	678	8.8	224	33.0	839	9.7	246	2				
		3	24.7	627	—	—	—	—	—	—	3				
	2100	1	31.7	804	—	—	38.7	984	—	—	1			2100	
		2	29.7	753	9.8	250	34.9	886	13.7	348	2				
		3	27.7	703	—	—	—	—	—	—	3				
	2500	1	33.9	860	—	—	38.2	971	—	—	1		2500		
		2	—	—	—	—	38.2	971	14.7	375	2				
		3	—	—	—	—	—	—	—	—	3				
2100 (Duplex)	1	31.7	804	—	—	38.7	984	—	—	1	2100 (Duplex)				
2500 (Duplex)	1	33.9	860	—	—	38.2	971	—	—	1	2500 (Duplex)				

Marine Waterbox Arrangement Tables

Table 13. Evaporator waterbox arrangement

EVWA	Inlet	Outlet
LFRF	LH Front	RH Front
RFLF	RH Front	LH Front
LRRR	LH Rear	RH Rear
RRLR	RH Rear	LH Rear
LFRR	LH Front	RH Rear
RFLR	RH Front	LH Rear
LRRF	LH Rear	RH Front
RRLF	RH Rear	LH Front

Note: Data based on looking at unit on control panel side.

Table 14. Condenser waterbox arrangement

CDWA	Inlet	Outlet
LFRF	LH Front	RH Front
RFLF	RH Front	LH Front
LRRR	LH Rear	RH Rear
RRLR	RH Rear	LH Rear
LTRT	LH Top	RH Top
RTL T	RH Top	LH Top
LBRB	LH Bottom	RH Bottom
RBLB	RH Bottom	LH Bottom
LFRR	LH Front	RH Rear
LFRT	LH Front	RH Top
LFRB	LH Front	RH Bottom
RFLR	RH Front	LH Rear
RFLT	RH Front	LH Top
RFLB	RH Front	LH Bottom
LRRF	LH Rear	RH Front
LRRT	LH Rear	RH Top
LRRB	LH Rear	RH Bottom
RRLF	RH Rear	LH Front
RRLT	RH Rear	LH Top
RRLB	RH Rear	LH Bottom
LTRF	LH Top	RH Front
LTRR	LH Top	RH Rear
LTRB	LH Top	RH Bottom
RTLF	RH Top	LH Front
RTL R	RH Top	LH Rear
RTL B	RH Top	LH Bottom
LBRF	LH Bottom	RH Front
LBRR	LH Bottom	RH Rear
LBRT	LH Bottom	RH Top
RBLF	RH Bottom	LH Front
RBLR	RH Bottom	LH Rear
RBLT	RH Bottom	LH Top

Note: Data based on looking at unit on control panel side.

Mechanical Specifications

Compressor

Guide Vanes

Fully modulating variable inlet guide vanes provide capacity control. The guide vanes are controlled by an externally-mounted electric vane operator in response to refrigeration load on the evaporator.

Impellers

Fully shrouded impellers made of high strength aluminum alloy are directly connected to the motor rotor shaft operating at 3,600 rpm (60 hertz) or 3,000 rpm (50 hertz). The impellers are dynamically balanced and over-speed tested at 4,500 rpm; the motor-compressor assembly is balanced to a maximum vibration of 0.15 inch/second at 3,600 rpm as measured on the motor housing.

Compressor Casing

Separate volute casings of refrigerant-tight, close-grained cast iron are used on the centrifugal compressor; each incorporating a parallel wall diffuser surrounded by a collection scroll. The diffuser passages are machined to ensure high efficiency. All casings are proof-and leak-tested.

Motor

Compressor motors are hermetically sealed two-pole, squirrel cage induction-type. They are built in accordance with Trane specifications and guaranteed by the manufacturer for continuous operation at the nameplate rating. A load-limit system provides protection against operation in excess of this rating. The rotor shaft is heat-treated carbon steel and designed such that the critical speed is well above the operating speed. The control circuit prevents motor energization unless positive oil pressure is established. Impellers are keyed directly to the motor shaft and locked in position. Nonferrous, labyrinth-type seals minimize recirculation and gas leakage between the stages of the compressor.

200- through 600-volt, three-phase 60-hertz and 380 through 415 volt, three-phase 50-hertz motors are supplied with six terminal posts for reduced-voltage wye-delta starting. For low-voltage, solid-state starters and AFDs—connecting links are furnished to convert the motor to a 3-lead motor.

2,300- volt through 13,800-volt, three-phase 60-hertz and 3,300 through 11,000 volt, three-phase 50-hertz motors are supplied with three terminal posts for full-voltage (across-the-line) or reduced-voltage (primary reactor or autotransformer) starting. Motor terminal pads are supplied. A removable sheet metal terminal box encloses the terminal board area.

Motor Cooling

Motor cooling is accomplished by a patented refrigerant pump that supplies liquid refrigerant to the motor. The refrigerant circulates uniformly over the stator windings and between the rotor and stator. All motor windings are specifically insulated for operation within a refrigerant atmosphere.

Lubrication

A direct-drive, positive-displacement oil pump is driven by a 120-volt, single-phase, 3/4-hp motor. The motor and pump assembly are submerged in the oil sump to assure a positive oil supply to the compressor bearings at all times. A low watt-density heater maintains the oil temperature to minimize its affinity for refrigerant.



Mechanical Specifications

Evaporator

Shell and Waterboxes

The evaporator shell is constructed of carbon steel plate and incorporates a carbon rupture disc in accordance with the ANSI/ASHRAE 15 Safety Code. A refrigerant temperature coupling is provided for a low limit controller, or customer use.

Multiple pass arrangements are available at 150 psig or 300 psig water side working pressures, with grooved connections. Flanged connections are also available. Marine-type waterboxes are available.

Tube Sheets

A thick carbon steel tube sheet is welded to each end of the shell and is drilled and reamed to accommodate the tubes. Three annular grooves are machined into each tube hole to provide a positive liquid and vapor seal between the refrigerant and water side of the shell after tube rolling. Intermediate tube support sheets are positioned along the length of the shell to avoid contact and relative motion between adjacent tubes.

Tubes

Individually replaceable, seamless copper tubing available in either one-inch or three-quarter-inch outside diameter is used as the evaporator heat transfer surface. Tubes are externally and internally enhanced, and mechanically expanded into the tube sheets (and are secured to the intermediate supports with tube clips) to provide a leak-free seal and eliminate tube contact and abrasion due to relative motion.

Eliminators

Multiple layers of metal mesh screen form the eliminators and are installed over the tube bundle along the entire length of the evaporator. The eliminators prevent liquid refrigerant carryover into the compressor.

Refrigerant Distribution

A refrigerant distributor on the base of the evaporator assures uniform wetting of the heat transfer surface over the entire length of the shell and under varying loads. High velocity, refrigerant-spray impingement on the tubes is prevented through this design.

Refrigerant Flow Control

A multiple orifice flow-control system maintains the correct pressure differential between the condenser, economizer, and evaporator over the entire range of loading. This patented system contains no moving parts.

Shell Tests

The refrigerant side of the evaporator shell, complete with tubes but without waterbox covers, is proof-tested at 45 psig, vacuum leak-tested, and finally pressure leak-tested with a helium mass spectrometer. The water side of the evaporator shell, with waterboxes in place, is hydrostatically tested at 1.5 times the design working pressure, but not less than 225 psig.

Note: *These tests are not to be repeated at installation.*

Condenser/Heat Recovery Condenser

Shell and Waterboxes

The condenser shell is constructed of carbon steel plate designed and constructed in accordance with ANSI/ASHRAE 15 Safety Code.

Multiple pass arrangements are available at 150 psig or 300 psig water side working pressures, with grooved connections. Flanged connections are also available. Marine-type waterboxes are available.

Tube Sheets

A thick carbon steel tube sheet is welded to each end of the shell and is drilled and reamed to accommodate the tubes. Three annular grooves are machined into each tube hole to provide a positive liquid and vapor seal between the refrigerant and water sides of the shell after tube rolling. Intermediate tube support sheets are positioned along the length of the shell to avoid contact and relative motion between adjacent tubes.

Tubes

Individually replaceable, seamless copper tubing available in either one-inch or three-quarter-inch outside diameter is used as the evaporator heat transfer surface. Tubes are externally and internally enhanced, and mechanically expanded into the tube sheets (and are secured to the intermediate supports with tube clips) to provide a leak-free seal and eliminate tube contact and abrasion due to relative motion.

Refrigerant Gas Distribution

A baffle plate between the tube bundle and the condenser shell distributes the hot compressor-discharge gas longitudinally throughout the condenser and downward over the tube bundle. The baffle plate prevents direct impingement of high velocity compressor-discharge gas upon the tubes.

Shell Tests

The refrigerant side of the condenser shell, complete with tubes, but without waterbox covers, is proof-tested at 45 psig, vacuum leak-tested, and finally pressure leak-tested with a helium mass spectrometer. The water side of the condenser shell, with waterboxes in place, is hydrostatically tested at 1.5 times the design working pressure, but not less than 225 psig.

Note: *These tests are not to be repeated at installation.*

Economizer

The CVHE/CVHG-style CenTraVac two-stage economizer (single-stage economizer on CVHF style units) is a series of interstage pressure chambers which utilize a multiple orifice system to maintain the correct pressure differential between the condenser, economizer, and evaporator over the entire range of loading. This patented system contains no moving parts. CDHG Duplex units use a two-stage economizer per circuit. CDHF Duplex units use a single-stage economizer per circuit.

Purge System

Standard Features

- 115 Vac, 50/60 Hz, 1-Phase.
- 175 watt carbon tank heater.
- 12.3 minimum circuit ampacity.
- 335 psig design pressure high side.

Mechanical Specifications

- 175 psig design pressure low side.
- The purge is 25-3/4-in. high, 27-1/2-in. wide, and 21-3/4-in. deep.
- The purge uses an R-404A refrigeration circuit with a 1/4-hp condensing unit/10.3 total unit amps (fan, compressor, expansion valve), and a compressor suction temperature sensor.

The purge tank has a fusible plug, evaporator coil, normally-closed float switch, and the following connections:

- 1/4-in. liquid return with filter-drier and moisture indicator
- 5/8-in. vapor line

The expansion valve automatically controls the purge suction pressure to 34 psia.

The pump-out system consists of a pump-out compressor, pump-out solenoid valve, and an exhaust solenoid valve.

The carbon bed tank incorporates a temperature sensor and a regenerative cycle, a 175-watt resistive heater, 150 psi pressure relief valve, and a temperature sensor. The carbon bed tank automatically collects and scrubs refrigerant molecules from the noncondensable gas and drives any collected refrigerant vapor back into the chiller. This design keeps the purge efficiency at peak levels throughout its life without the maintenance required on other purges.

The purge controller interfaces with the following intelligent devices on an IPC3 communications link: liquid-level switch, dual relay output, quad relay output, dual triac output, suction temperature sensor, and carbon temperature sensor. 50 Hz applications have a separate voltage correction transformer.

The purge controller communicates with the Tracer AdaptiView controller and display, which mounted on the front of the chiller control panel. Descriptive text indicates purge operating mode, status, set points, purge operating data reports, diagnostics, and alarms. Operating modes Stop, On, Auto, and Adaptive operate the purge refrigeration circuit and accumulate noncondensables with or without the chiller running.

Chiller Controller

The microcomputer control panel is factory installed and tested on the CenTraVac unit. All controls necessary for the safe and reliable operation of the chiller are provided including oil management, purge operation, and interface to the starter or AFD. The control system is powered by a control power transformer included in the starter panel. The microcomputer control system processes the leaving evaporator fluid temperature sensor signal to satisfy the system requirements across the entire load range.

The microprocessor controller is compatible with reduced-voltage or full-voltage electromechanical starters, variable-speed drives, or solid-state starters. Depending on the applicability, the drives may be factory mounted or remote mounted.

The controller will load and unload the chiller via control of the stepper motor/actuator which drives the inlet guide vanes open or closed. The load range can be limited either by a current limiter or by an inlet guide vane limit (whichever controls the lower limit). It will also control the evaporator and condenser pumps to insure proper chiller operation.

Approximately 200 diagnostic checks are made and displayed when a fault is detected. The display indicates the fault, the type of reset required, the time and date the diagnostic occurred, the mode in which the machine was operating at the time of the diagnostic, and a help message. A diagnostic history displays the last 10 diagnostics with the time and date of their occurrence.

The panel features machine protection shutdown requiring **manual** reset for:

- Low oil flow
- Low oil temperature
- Actuator drive circuit fault
- Low differential oil pressure
- Extended compressor surge

- Excessive loss of communication
- High condenser refrigerant pressure
- Critical sensor or detection circuit faults
- Low evaporator refrigerant temperature
- Free-cooling valve closure failure (free cooling applications only)

The display also provides reports that are organized into six groupings: Evaporator, Condenser, Compressor, Motor, Purge, and the ASHRAE Chiller Log. Each report contains data that is accessed by scrolling through the menu items. Each grouping will have a heading which describes the type of data in that grouping. This data includes:

- Phase currents
- Last 10 diagnostics
- Phase voltages
- Current limit setpoint
- Water flows (optional)
- Purge suction temperature
- Oil temperature and pressures
- Motor winding temperatures
- Current chiller operating mode
- Water pressure drops (optional)
- Watts and power factor (optional)
- Bearing temperatures (optional)
- Outdoor air temperature (optional)
- Evaporator refrigerant liquid level
- All water temperatures and setpoints
- Condenser liquid refrigerant temperature
- Compressor starts and hours running
- Saturated refrigerant temperatures and pressures
- Refrigerant detection external to chiller in ppm (optional)
- Control source (i.e., local panel, external source, remote BAS)

The controller is capable of receiving signals from a variety of control sources (which are not mutually exclusive—i.e., multiple control sources can coexist simultaneously) and of being programmed at the keypad as to which control source has priority. Control sources can be:

- Tracer SC building automation system (interface optional)
- The local operator interface (standard)
- A 4–20 mA or 2–10 Vdc signal from an external source (interface optional, control source not supplied by chiller manufacturer)
- Process computer (interface optional, control source not supplied by chiller manufacturer)
- Generic BAS (interface optional, control source not supplied by chiller manufacturer)

The control source with priority will then determine the active setpoints via the signal that is sent to the control panel.

Isolation Pads

Isolation pads are supplied with each CenTraVac chiller for placement under all support points. They are constructed of molded neoprene.

Refrigerant and Oil Charge

A full charge of refrigerant and oil is supplied with each unit. The oil ships in the unit's oil sump and the refrigerant ships directly to the job site from refrigerant suppliers.



Mechanical Specifications

0.0% Leak-Tight Warranty

The CenTraVac™ chiller features a 5-year limited Leak-Tight Warranty which is valid for the lesser of 60 months from initial start-up or 66 months from date of shipment. The limited Leak-Tight Warranty covers models CVHE/F/L, CVHS and CDHF chillers installed in the United States or Canada. The Company's obligations and liabilities under this warranty are limited to furnishing replacement refrigerant; no other parts or labor are covered under this limited warranty. No liability whatever shall attach to the Company until appropriate actions have been taken (acceptable to Company) to eliminate the source of the leak, and then said liability shall be limited to furnishing the replacement refrigerant.

If the chiller is placed under a comprehensive Trane service and maintenance agreement (Trane "Select Agreement" or better) prior to the expiration of the standard Leak-Tight Warranty, the protection against refrigerant loss shall continue under the Trane Select Agreement for as long as an active Trane Select Agreement remains in effect without interruption.

If a 10-Year Parts, Labor and Refrigerant Warranty was purchased for the chiller and the chiller is placed under a Trane Select Agreement (or better) prior to the expiration of the 10-Year Parts, Labor and Refrigerant Warranty, the protection against refrigerant loss shall continue under the Trane Select Agreement for as long as an active Trane Select Agreement remains in effect without interruption.

Thermometer Wells and Sight Glasses

In addition to the thermowells provided for use with the standard unit safety controls, a well is provided for measurement of the liquid refrigerant condensing temperature and a coupling for the evaporating temperatures. Sight glasses are provided for monitoring oil charge level, oil flow, compressor rotation, and purge condenser drum.

Insulation

Factory applied insulation is available as an option on all units. All low temperature surfaces are covered with 3/4-in. Armaflex II or equal (thermal conductivity = 0.28 Btu/h-ft²), including the evaporator, waterboxes, and suction elbow. The economizer and motor cooling lines are insulated with 3/8-in. and 1/2-in. insulation respectively.

Refrigerant Pumpout/Reclaim Connections

Connections are factory-provided as standard to facilitate refrigerant reclaim/removal required during maintenance or overhaul in accordance with ANSI/ASHRAE 15.

Painting

All painted CenTraVac chiller surfaces are coated with two coats of air-dry beige (primer and finish top coat) solvent-based enamel paint prior to shipment.

Unit-Mounted Starter Options

Low-voltage (200V–600V) unit-mounted starters can be wye-delta, solid-state, or adaptive frequency drive in a NEMA 1 enclosure.

Medium-voltage starters (2,300V) are available to unit-mount on most sizes in full-voltage, primary reactor, or autotransformer.

Unit-Mounted, Refrigerant Cooled Adaptive Frequency Drive (AFD)

The Trane AFD is a closed loop, liquid cooled, microprocessor-based PWM design. The AFD is both voltage- and current-regulated. The output power devices are IGBT transistors.

The AFD is factory mounted on the chiller and ships completely assembled, wired, and tested. Patented Trane AFD control logic is specifically designed to interface with the centrifugal chiller controls. AFD control adapts to the operating ranges and specific characteristics of the chiller, and chiller efficiency is optimized by coordinating compressor motor speed and compressor inlet guide vane position. The chilled-water control and AFD control work together to maintain the chilled-water setpoint, improve efficiency and avoid surge. If surge is detected, AFD surge avoidance logic makes adjustments to move away from and avoid surge at similar conditions in the future.

Standard Design Features for All Trane AFDs

- Soft start, linear acceleration, coast-to-stop.
- Simple modular construction.
- Adjustable frequency from 38 hertz to 60 hertz.
- Minimum efficiency of 97 percent at rated load and 60 hertz.
- AFD can be started without a motor connected.
- 150 percent instantaneous torque available for improved surge control.
- Output line-to-line and line-to-ground short-circuit protection.
- Motor thermal overload protection 102 percent continuous, 140 percent for 1.5 seconds, 108 percent for 60 seconds.
- All control circuit voltages are physically and electrically isolated from power circuit voltage.
- The drive is rated for 380–480V 50/60 Hz three-phase input power, ± 10 percent, with a drive overload capability of 100 percent continuous to 150 percent for five seconds.
- NEMA 1 ventilated enclosure with a hinged, latching door with a short-circuit withstand rating of 65,000 amps. It includes a padlockable door-mounted circuit breaker/shunt trip with AIC rating of 65,000 amps. The entire package is UL/CUL listed.

Chiller Unit Controller Features for all Trane AFDs

The chiller unit controller capabilities provide for the control/configuration and the retrieval/display of AFD-related data. AFD standard design features controlled through the chiller controller included:

- Current limited to 107 percent.
- Motor overload protection.
- Phase loss, reversal, imbalance protection.
- Motor overtemperature protection.
- Over/undervoltage protection.
- Loss of follower signal—in the event of loss of input speed signal the AFD will default to 38 hertz or hold speed based on last reference received.
- Output speed reference via IPC3 communication bus from the chiller controller to the AFD.
- Digitally displayed on the chiller controller: line and motor frequency in hertz, output speed in rpm, input-line-voltage, line and motor power in kW, output-load amps, average input current in amps, average motor current in % RLA, load power factor, AFD transistor temperature.

Environmental Ratings

- 32°F to 104°F (0°C to 40°C) operating ambient temperature
- Humidity, 95 percent non-condensing



Mechanical Specifications

- Altitude to 3,300 feet (1,000 m), amperage derate of 1 percent per every 300 feet above 3,300 feet

Unit-Mounted Refrigerant-Cooled Trane AFD Design Features

- A near unity displacement power factor of 0.96 or better at all loads.
- Integrated active rectification control of the building AC power assures low line-generated harmonics back to the user's power grid. The Trane AFD has ≤ 5 percent total demand distortion.

Standard Conversion Table

To Convert From:	To:	Multiply By:
Length		
Feet (ft)	meters (m)	0.30481
Inches (in)	millimeters (mm)	25.4
Area		
Square feet (ft ²)	square meters (m ²)	0.093
Square inches (in ²)	square millimeters (mm ²)	645.2
Volume		
Cubic feet (ft ³)	cubic meters (m ³)	0.0283
Cubic inches (in ³)	cubic mm (mm ³)	16387
Gallons (gal)	liters (L)	3.785
Gallons (gal)	cubic meters (m ³)	0.003785
Flow		
Cubic feet/min (cfm)	cubic meters/second (m ³ /s)	0.000472
Cubic feet/min (cfm)	cubic meters/hr (m ³ /h)	1.69884
Gallons/minute (gpm)	cubic meters/hr (m ³ /h)	0.2271
Gallons/minute (gpm)	liters/second (L/s)	0.06308
Velocity		
Feet per minute (fpm)	meters per second (m/s)	0.00508
Feet per second (fps)	meters per second (m/s)	0.3048
Energy, Power, and Capacity		
British thermal units per hour (Btu/h)	kilowatt (kW)	0.000293
British thermal units per hour (Btu)	kilocalorie (kcal)	0.252
Tons (refrig. effect)	kilowatt (refrig. effect)	3.516
Tons (refrig. effect)	kilocalories per hour (kcal/hr)	3024
Horsepower	kilowatt (kW)	0.7457
Pressure		
Feet of water (ft H ₂ O)	pascals (Pa)	2990
Inches of water (in H ₂ O)	pascals (Pa)	249
Pounds per square inch (PSI)	pascals (Pa)	6895
PSI	bar or kg/cm ²	6.895 x 10 ⁻²
Weight		
Ounces	kilograms (kg)	0.02835
Pounds (lb)	kilograms (kg)	0.4536
Fouling factors for heat exchangers		
0.00085 ft ² · °F · hr/Btu	= 0.132 m ² · °K/kW	
0.00025 ft ² · °F · hr/Btu	= 0.044 m ² · °K/kW	

Conversions

Scale	Temperature		Temperature Interval			
	°C	°F	°C	°F		
Celsius	x °C =	x	1.8x + 32	1 °C =	1	9/5 = 1.8
Fahrenheit	x °F =	(x-32) / 1.8	x	1 °F =	5/9	1



Trane optimizes the performance of homes and buildings around the world. A business of Ingersoll Rand, the leader in creating and sustaining safe, comfortable and energy efficient environments, Trane offers a broad portfolio of advanced controls and HVAC systems, comprehensive building services, and parts. For more information, visit www.Trane.com.

Trane has a policy of continuous product and product data improvement and reserves the right to change design and specifications without notice.